

Road Force Touch™ Wheel Balancer

HUNTER
Engineering Company

SPECIFICATIONS



**RFT23™
Shown**

Power Requirements	196-253V, 10 amp, 50/60 Hz, 1 ph (Power cable includes: NEMA 20 amp plug, L6-20P)
Air Supply Requirements	100-175 psi (7-12 bar)
Roller Force	Variable up to 1,250 lbs (567 kg)
Capacity	
Rim Width	1.5 in to 20.5 in (38 mm to 521 mm)
Rim Diameter	10 in to 30 in (254 mm to 762 mm)*
ALU	14 in to 40 in (356 mm to 1016 mm)*
Max. Tire Diameter	40 in (1016 mm)
Max. Tire Width	20 in (508 mm)
Max. Tire Weight	175 lbs (79 kg)
Radial and Lateral Runout Accuracy	0.002 in (0.051 mm)
Imbalance Resolution	± 0.01 oz (0.28 g)
Placement Accuracy	512 positions, ± 0.35°
Balancing Speed	300 rpm
Motor	Programmable drive system and DC motor

* Extreme wheel sizes may require manual data entry.

MODEL ** FEATURES / DIMENSIONS

	RFT33	RFT32	RFT31	RFT30	RFT23	RFT22	RFT21	RFT20	RFT13	RFT12	RFT11	RFT10	RFT03	RFT02	RFT01	RFT00
Wheel Lift System	✓	✓	✓	✓					✓	✓	✓	✓				
AutoClamp® System	✓	✓	✓	✓	✓	✓	✓	✓								
TDC Laser System	✓	✓			✓	✓			✓	✓			✓	✓		
Ink Jet Print w/Storage	✓		✓		✓		✓		✓		✓		✓		✓	
Width (W)	73 in 1854 mm	67 in 1702 mm	73 in 1854 mm	67 in 1702 mm	65 in 1651 mm	58 in 1473 mm	65 in 1651 mm	56.5 in 1435 mm	73 in 1854 mm	67 in 1702 mm	73 in 1854 mm	67 in 1702 mm	65 in 1651 mm	56.5 in 1435 mm	65 in 1651 mm	56.5 in 1435 mm
Height (H)	89 in 2261 mm	89 in 2261 mm	73 in 1854 mm	73 in 1854 mm	89 in 2261 mm	89 in 2261 mm	73 in 1854 mm	73 in 1854 mm	89 in 2261 mm	89 in 2261 mm	73 in 1854 mm	73 in 1854 mm	89 in 2261 mm	89 in 2261 mm	73 in 1854 mm	73 in 1854 mm
Depth (D)	62 in 1575 mm	62 in 1575 mm	62 in 1575 mm	62 in 1575 mm	62 in 1575 mm	62 in 1575 mm	62 in 1575 mm	62 in 1575 mm	62 in 1575 mm	62 in 1575 mm	62 in 1575 mm	62 in 1575 mm	62 in 1575 mm	62 in 1575 mm	62 in 1575 mm	62 in 1575 mm
Weight	974 lb 442 kg	921 lb 418 kg	924 lb 419 kg	871 lb 395kg	842 lb 382 kg	789 lb 358 kg	792 lb 359 kg	739 lb 335 kg	899 lb 408 kg	846 lb 384 kg	849 lb 385 kg	796 lb 361 kg	844 lb 383 kg	791 lb 359 kg	794 lb 360 kg	741 lb 336 kg

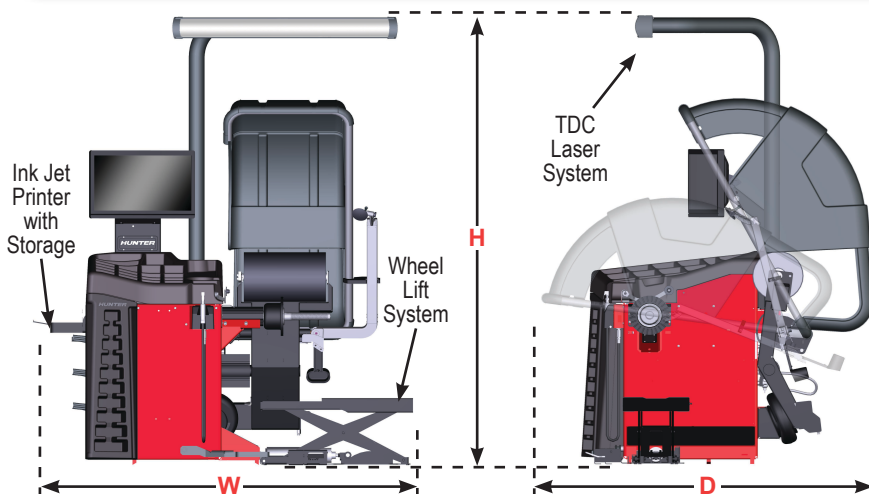

**Road Force Touch™ model numbers are trademarks of Hunter Engineering Company.

For balancer information visit:
www.hunter.com/balancer
and
www.gsp9700.com

For local contact visit:
www.hunter.com/company/findrep.cfm

For general inquiries visit:
www.hunter.com
or call
800-448-6848

Because of continuing technological advancements, specifications, models and options are subject to change without notice.

Form 6475-T, 01-15
Supersedes Form 6475-T, 10-14
Copyright © 2012-15, Hunter Engineering Company