

REWORK INSTRUCTIONS

HOIST PADS 501-425



BOSCH
Invented for life

Special tool 501-425 (Adapter Set, Hoist Pads Lift), has been supplied with bolts that do not meet the specified maximum torque: 27-33 Nm, which is engraved in the tooling.
If supplied bolts are tightened in the referred torque range, they could break.

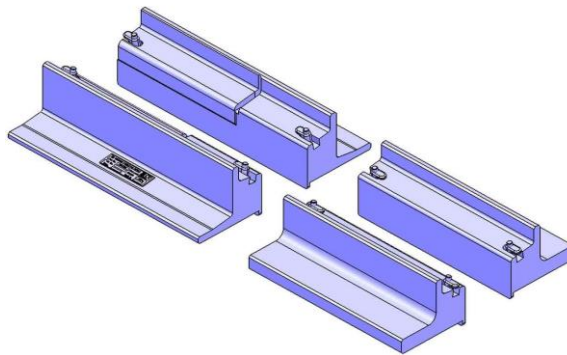

All shipments of 501-425 prior to June 2nd 2022 are to the wrong bolt specification.

Once you have received the new bolts and retaining feet from Bosch, please exchange the old bolts and retaining feet by following these steps:

Disassembly



Position the hoist pad with retaining feet facing down on a work bench or table top in such a way that the pad is supported against the edge of the table. The retaining feet should rest in the groove and must not twist or turn. Loosen the bolt and unscrew. Unscrewing can be somewhat tricky as the caulking of the first threads has to be overcome. Hoist pads and springs are to be re-used.



Dispose of the 8.8 bolts and retaining feet.

REWORK INSTRUCTIONS HOIST PADS 501-425



BOSCH
Invented for life

Re-assembly

Only use the new 12.9 bolts and retaining feet (501-425/6KIT) for the re-assembly.

When screwing in the new bolts, make sure that the retaining feet are correctly aligned and that the springs are seated. Important: Both feet must point in the same direction as indicated by the arrow on the hoist pad!

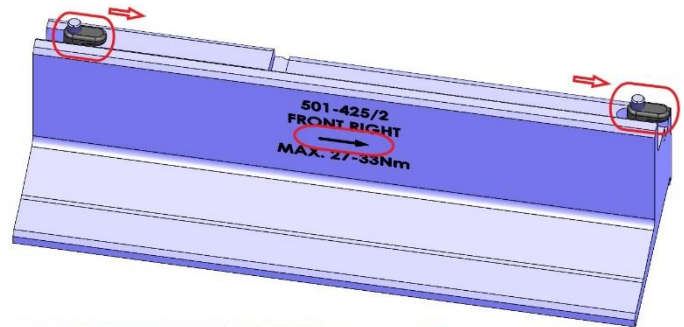

REWORK INSTRUCTIONS HOIST PADS 501-425



BOSCH
Invented for life

Tightening the bolts is easier now as no caulking is in place as a means of „loss protection“.

Attention: Do not completely loosen or unscrew the bolts when using the tool as the retaining feet could fall out and remain in the vehicle rocker panel.

We therefore highly recommend you caulk or notch the first thread of each bolt with a flat chisel after you have assembled the bolts and the retaining feet.

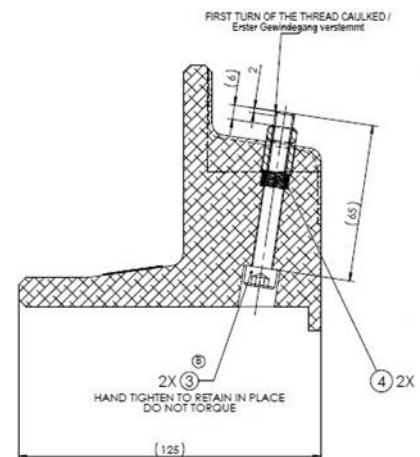
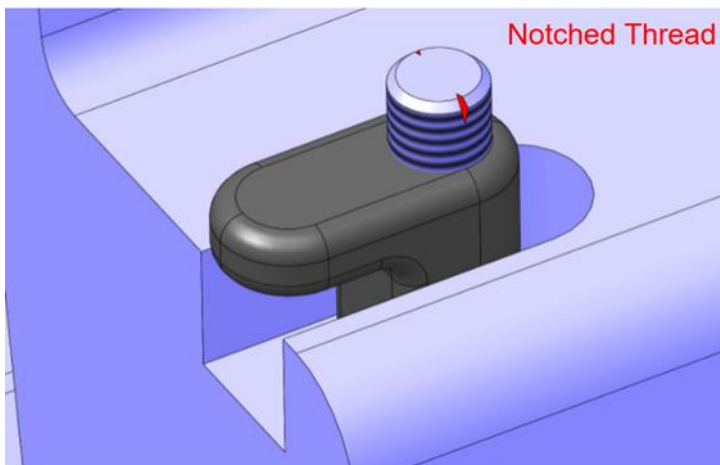

[Rework-Video](#)