



AUTOBETANKUNG



ABGABEEINHEITEN



PUMPEN



ZÄHLER



ZAPFVENTILZÄHLER



ZAPFVENTILE

PIUSIBOX CAR SUCTION

MERKMALE

- IDEAL ZUM ENTLEREEN VON FAHRZEUGTANKS
- VERMEIDET TANKÜBERFÜLLUNG
- SUZZARABLUE MEMBRANPUMPE
- LEICHT MANÖVRIERBAR

Die PIUSI BOX Car Suction ist die perfekte Lösung zum Entleeren von AdBlue®-Fahrzeugtanks vor der Wartung. Wird mit einer tragbaren Box geliefert, die alles Erforderliche enthält.

LEISTUNGSPARAMETER

bis zu
34 L/MIN

VOLUMENSTROM

Stromversorgung
AC

SPANNUNG

max.
2 M
gebunden
SCHLAUHLÄNGE



PIUSIBOX CAR SUCTION

VERPACKUNG

CODE	GEWICHT		VERPACKUNG		
	KG	LBS	MM	ZOLL	STCK./KARTON
FOO201R20	11,5	25,3	650X400X450	25,6X15,7X17,7	1



FILTRATION



FLÜSSIGKEITS-
ÜBERWACHUNG



SCHLAUCH-
AUFROLLER



ZUBEHÖR



WERBEARTIKEL

INDEX

- A LUFT
- A FROSTSCHUTZ
- Ad AdBlue®
- B BIODIESEL
- D DIESEL
- F LEBENSME.
- G BENZIN
- G SCHMIERM.
- K KEROSIN
- O ÖL
- W WASSER
- W WISCHERFLÜSS.

SCHWERPUNKT

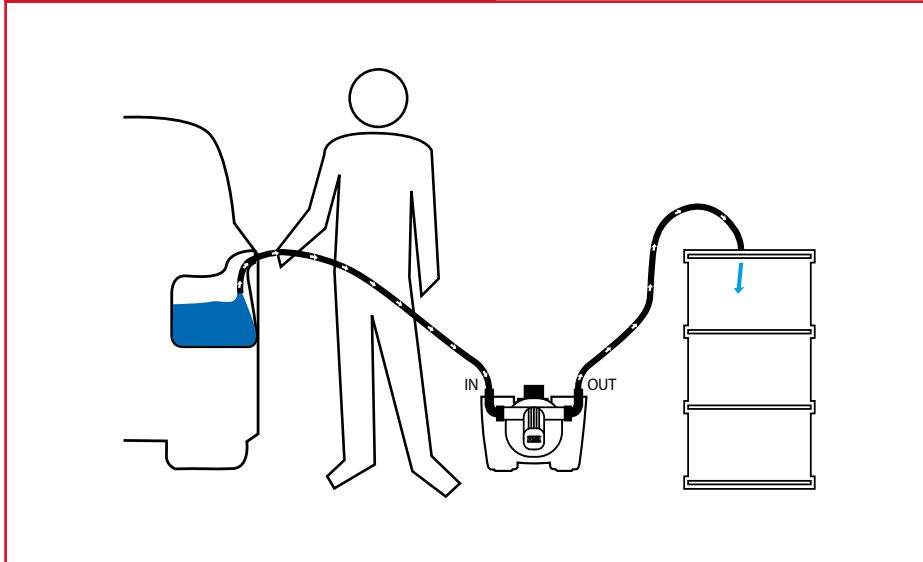

LIEFERUMFANG

- SUZZARABLU PUMPE
- ANSAUG- /
VERSORGUNGSSCHLAUCH
- BEDIENUNGSANLEITUNG

ABMESSUNGEN

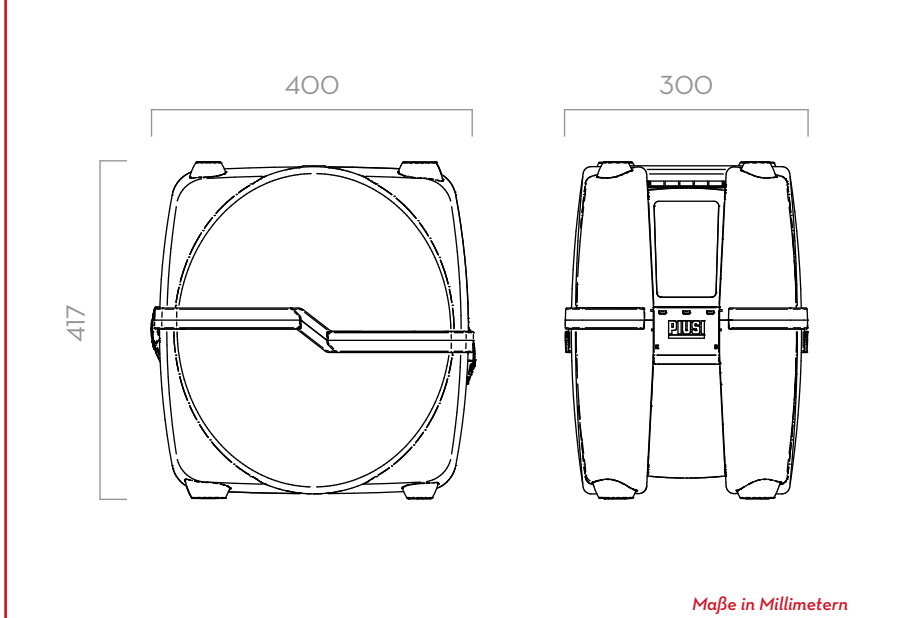

DETAILS

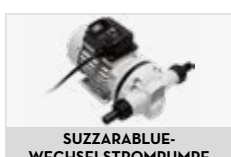

MATERIALIEN

- GEHÄUSE: POLYPROPYLEN
- MEMBRAN: POLYPROPYLEN

TECHNISCHE DATEN

CODE	BESCHREIBUNG	FLÜSSIGKEITS- ART	VOLUMEN- STROM		SPANNUNG			DREHZAHL MIN-1	ARBEITSZY- KLUS MIN	KABEL	ANSAUG- SCHLAUCH Ø 12 MM LÄNGE	VERSOR- GUNGSSCHLAUCH Ø 12 MM LÄNGE
			L/MIN	GPM	AC V./HZ DC VOLT	LEISTUNG W	A. MAX.					
FOO201R20	PIUSIBOX CAR SUCTION ADBLUE	Ad	34	9	230/50	400	1,95	1450	20	JA	2	2 M

PIUSIBOX CAR SUCTION