

**blink**<sup>®</sup>

LEVEL 2 AC EV

# IQ 200

CHARGING STATIONS

SPECIFICATIONS



# Level 2 AC EV Charging Stations

**The Blink IQ 200 Product Family** is a collection of Level 2 AC Electric Vehicle (EV) charging stations. The products offer a modern and stylish appearance, the versatility of multiple charging current options, the ability to be installed in wall-mounted and pedestal-mounted configurations, and a peer-to-peer communications architecture which provides the ability to support a single primary charging station (or Kiosk) and multiple secondary charging stations.

## FEATURES

### Blink IQ 200 Unique Design

- Future-proof design supports charging currents from 12A to 80A
- Intuitive charge connector holster provides protection and storage
- Multi-colored high visibility illuminator indicates charging station's status
- Convenient cable management design supports a long reach and storage between uses
- Height design conforms with ADA requirements
- Fee options include time-based, kWh-based, or session-based billing functionality
- Payment methods: RFID, Apple Pay, Google Wallet, and all major credit cards
- Pedestal accessories include single, dual, and triple port options
- OCPP support
- Updated 25ft. cable with an ergonomic design
- Button locking mechanism prevents accidental disconnection

### Touch Screen

- Daylight readable 7" color LCD with touch screen and 800 x 480 resolution
- Convenient, user-friendly user interface
- Displays charging station status and transaction details
- Pre-loaded with the Blink commercial user interface

### Type 2 Charger Connector

- SAE J1772 Charge Connector (Standard in the United States)
- Grounded pole – first to make contact, last to break contact
- Designed for more than 10,000 cycles
- Can withstand being driven over by a vehicle
- Safe for use in wet or dry locations
- Compatible with integrated charge connector holster



# Level 2 AC EV Charging Stations

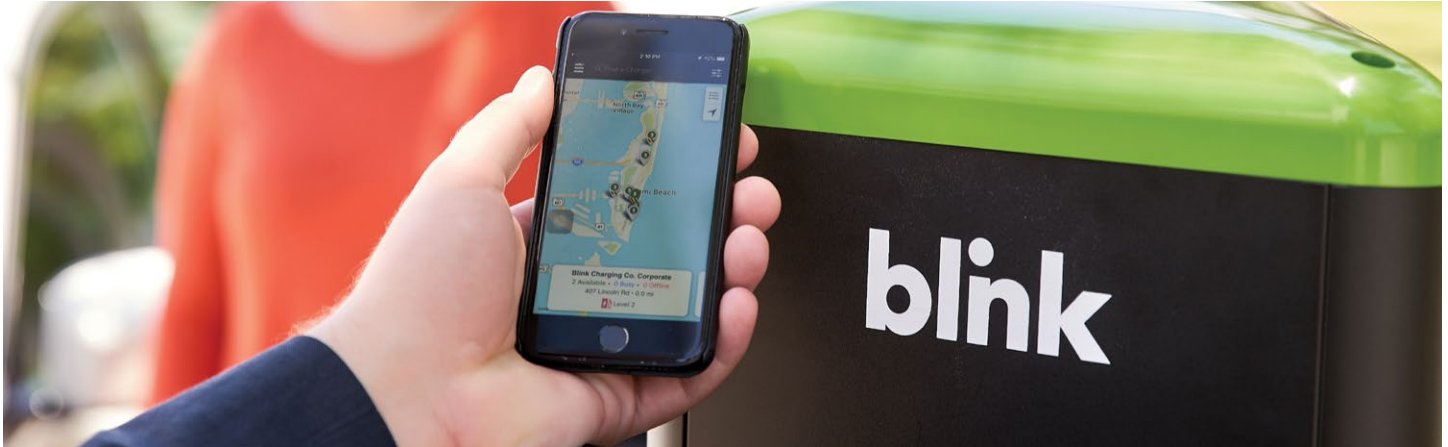

## Energy Management

- Internal meter to monitor energy and demand usage
- Supports real-time energy usage data evaluation
- Controllable output to support utility demand response requests
- Local load management capability for optimal energy outputs

## Network, Product, and Customer Support

- Multiple modes of communication, including Wi-Fi and cellular
- Over-the-air firmware management enables remote updates
- Blink Customer Support Center with tracking system
- Blink Network Operations Center actively monitors/manages network
- Smart grid implementation and support for commercial use
- Smart-phone applications for status changes and notifications
- Role-based features to manage permissions and access levels
- Ability to manage multiple chargers with detailed data sets

- Secure, high-availability, enterprise-grade infrastructure
- Geographically separated secondary systems for disaster recovery and management

## Safety and Compliance

- Ground monitoring circuit
- Charge circuit interrupting device (CCID) with automatic test
- Nuisance tripping avoidance and auto re-closure
- Cold load pickup (randomized auto-restart following a power outage)

## Promotion and Advertising

In addition to promoting locations and Blink charging stations to EV drivers across the country via the Blink Mobile App and Blink Map, the Blink IQ 200 charging stations support the opportunity to promote and/or advertise businesses, properties, products, and services.

- Rich multimedia touch screen can be easily customized via Blink Ad Loop functionality
- Station panels can also be customized for branding and advertising and can be updated as necessary

# Charging Stations Comparison

BLINK IQ 200 PRODUCT SPECIFICATIONS				
MODELS	SMART CHARGING STATION		ADVANCED CHARGING STATION	KIOSK
Model Number	QW2-80U-W1-N1-N-25		IQW2-80U-M1-R2-N-25	IQW2-00U-M1-R2-N-00
Part Number	01-0205		01-0207	01-0208
POWER SPECIFICATIONS				
Standby Power	<10W Standby			<10W Standby
Output Power (kW)	2.9kW	3.8kW	5.8kW 7.7kW 9.6kW 15.4kW 17.3kW 19.2kW	Not Applicable
Output Amperage (A)	12A	16A	24A 32A 40A 64A 72A 80A	Not Applicable
Circuit Breaker Options (A)	15A	20A	30A 40A 50A 80A 90A 100A	15A or 20A
Input/Output Nominal Voltage	208VAC/240VAC			120 Input
Input / Output Voltage Range	180VAC to 264VAC			90 to 132VAC Input; 180 to 264 VAC Input
Input / Output Frequency	60Hz			
Input Wiring Type	Hardwired			
Input Wiring Scheme	L1, L2, GND			L1, N, GND or L1, L2 GND
Cold-Load	Pickup Randomized delay between 120 and 720 seconds before charge resumes after a power failure.			Not Applicable
Power Measurement Accuracy	Embedded meter with a $\pm 1\%$ accuracy at the nominal input.			Not Applicable
Surge Protection	Up to 6kV at 3,000A			
FUNCTIONAL SPECIFICATIONS				
Charge Connector Type	SAE J1772			Not Applicable
Charge Cable Length	25 ft.			Not Applicable
Demand Response	Yes <sup>2</sup>			Not Applicable
Status Indicator	LED and Audio			
User Interface	None <sup>1</sup>	LCD, 7", Color, 800x480, w/Touch Panel		
Access Control	None <sup>1</sup>	Contactless Reader: RFID Cards: ISO/IEC 14443A/B, ISO/IEC 15693, MIFARE Plus, HID iCLASS, NEMA Smart Credit Cards <sup>2</sup> : Visa, Master Card, Discover, American Express NFC <sup>2</sup> : ISO 18092, Apple Pay, Google Wallet		
NETWORK SPECIFICATIONS				
Local Area Network (LAN)	2.4GHz Wi-Fi (802.11 b/g/n)			
Wide Area Network (WAN)	None	Cellular (3G GSM, 3G CDMA)		
Network Interface	Blink OCPP, OCPP 1.6J			
Mounting Type	Pedestal or Wall Mount			
SAFETY & COMPLIANCE SPECIFICATIONS				
Ground Fault Detection	CCID20, 20mA per UL 2231, Automatic Reset Feature and Manual Reset Feature			Not Applicable
Ground Monitor	Ground Monitor per UL 2231			Not Applicable
Safety Compliance	UL and cUL, NEC Article 625, RoHS, Norma Oficial Mexicana (NOM)			
Protection	Over-Voltage Protection (OVP), Under-Voltage Protection (UVP), Over-Current Protection (OCP), Over-Temp Protection (OTP), Short-Circuit Protection			
EMC Compliance	FCC Part 15 Class B, Industry Canada (IC), PTCRB			
ADA Compliance	Yes			
Energy Star Certified	Yes			Not Applicable
OPERATIONAL SPECIFICATIONS				
Enclosure Rating	NEMA Type 3R Indoor/Outdoor			
Operating Temperature	-30°C to +50°C (-22°F to +122°F)			
Storage Temperature	-40°C to +80°C (-40°F to +176°F)			
Operating Humidity	0 to 95% Relative Humidity, Non-Condensing			
Charger Dimensions	13.95"H x 10.65"W x 5.23"D			
Package Dimensions	19.57"L x 14.92"W x 16.61"D	19.57"L x 14.92"W x 16.61"D		19.57"L x 14.92"W x 10.63"D
Charger Weight (Unpackaged)	24.2lbs. (11kg)	25.3lbs. (11.5kg)		8.8lbs. (4kg)
Charger Weight (Packaged)	30lbs. (13.6kg)	31lbs. (14kg)		10lbs. (4.5kg)

Blink Charging Co. reserves the right to alter product offerings and specifications at any time without notice, and is not responsible for typographical or graphical errors that may appear in this document.

<sup>1</sup>If applicable, an adjacent primary Advanced Charging Station or Kiosk can provide access control for up to 20 secondary Smart Charging Stations.

<sup>2</sup>May not be included in the initial product offering.

# Pedestal Specifications

## BLINK IQ 200 PEDESTAL SPECIFICATIONS

MODELS	RECTANGLE, SINGLE	RECTANGLE, DUAL	TRIANGLE, DUAL	TRIANGLE, TRIPLE
Model Number	01-0210	01-0211	01-0212	01-0213
Number of Supported Charging Stations	1	2	2	3
User Interface Height	48"	48"	48"	48"
Pedestal Dimensions	56.04" H x 13.58" W x 4.28" D	56.04" H x 13.58" W x 4.28" D	59.00" H x 12.50" W x 11.19" D	59.00" H x 12.50" W x 11.19" D
Pedestal Weight (unpackaged)	TBD	TBD	TBD	TBD
Pedestal Weight (packaged)	TBD	TBD	TBD	TBD



### Rectangle Pedestal

The rectangle pedestal slim installation is great for small spaces that may wish to expand in the future.

### Triangle Pedestal

Maximizing space, the triangle pedestal can securely mount 1-3 independent charging stations.

### Triangle Pedestal – Dual Port

Dual Port Using the triangle pedestal, the dual port unit features 1 advanced and 1 or 2 smart chargers.

# IQ 200 Smart Units

The IQ 200 design allows for multiple deployment configurations including the innovative and cost-saving Smart/Kiosk units for high density, multiple unit, and fleet installations. Up to 20 Smart units can be connected to one Kiosk unit in which the charging session is initiated.



Wall Mount with Kiosk



Pedestal with Kiosk



# UI and Network Architecture Options

## USER INTERFACE OPTIONS

### Kiosk

- Driver plugs in vehicle then proceed to Kiosk
- Kiosk controls all charging stations
- Up to 20 smart charging stations per Kiosk

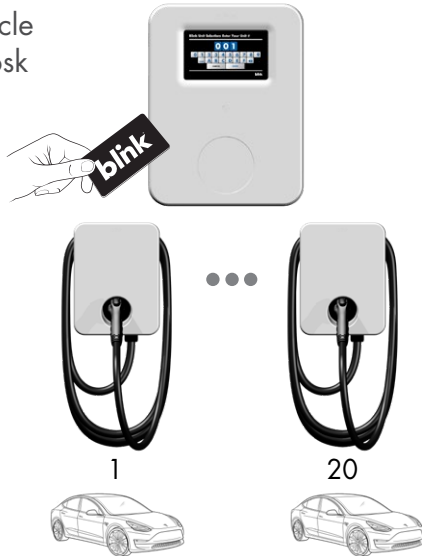

### Standalone

- Driver plugs in vehicle then utilizes the UI within the Blink Advanced Charging Station
- Each station operates independently

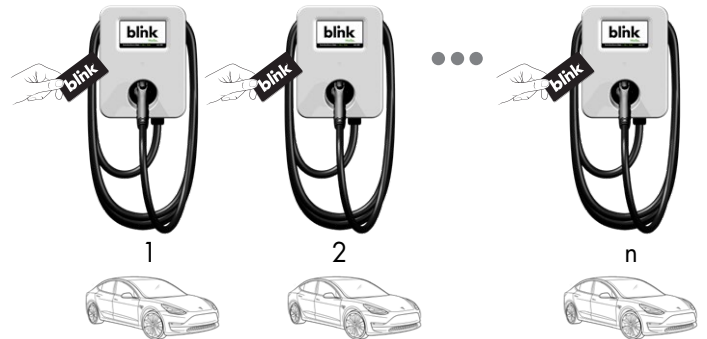

## NETWORK ARCHITECTURE OPTIONS

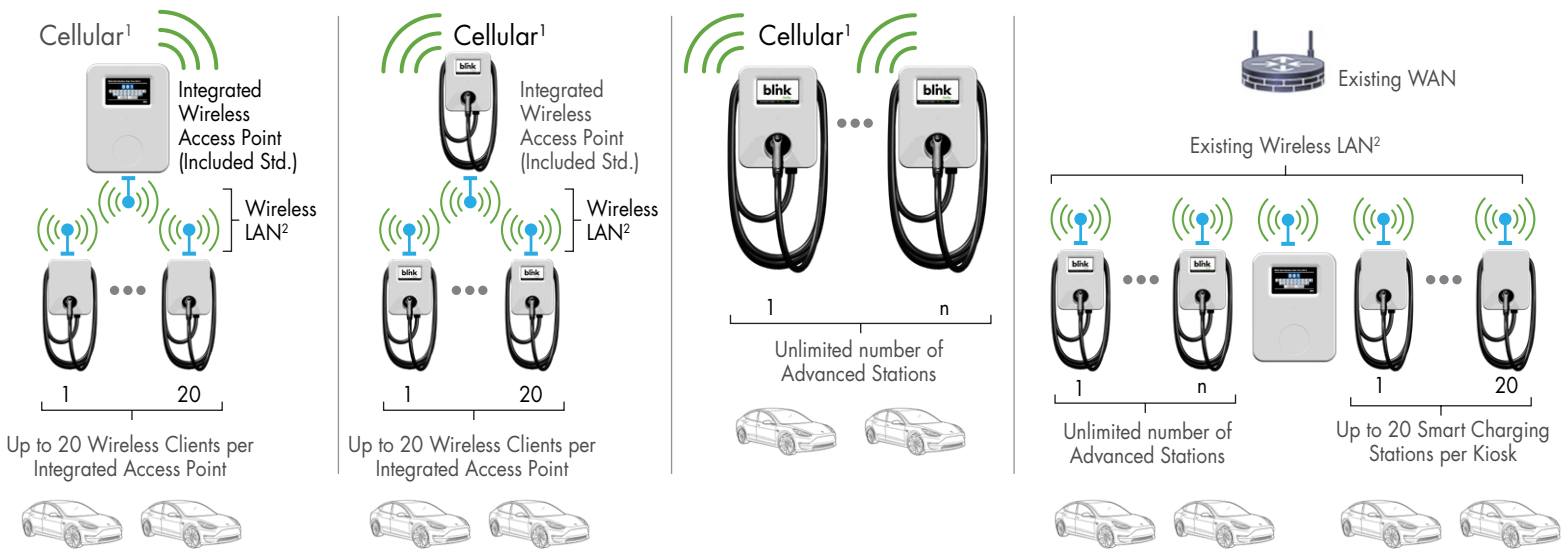

<sup>1</sup>Cellular 3G GSM / CDMA Capable  
<sup>2</sup>Integrated Wireless LAN is 802.11 b/g/n capable

# Pedestal Base Hole Pattern

## RECTANGULAR PEDESTAL BASE HOLE PATTERN

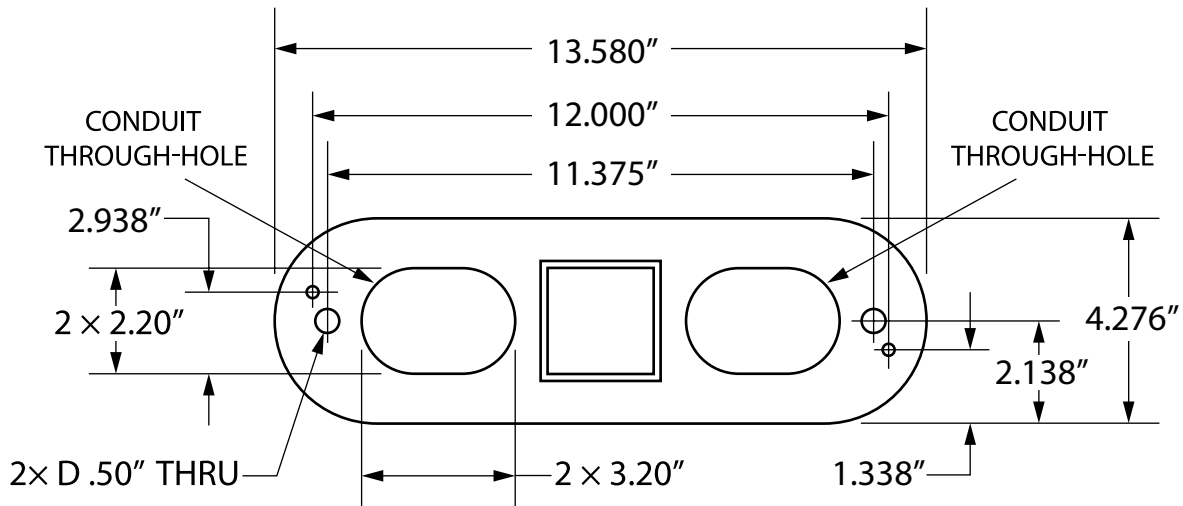

## TRIANGULAR PEDESTAL BASE HOLE PATTERN

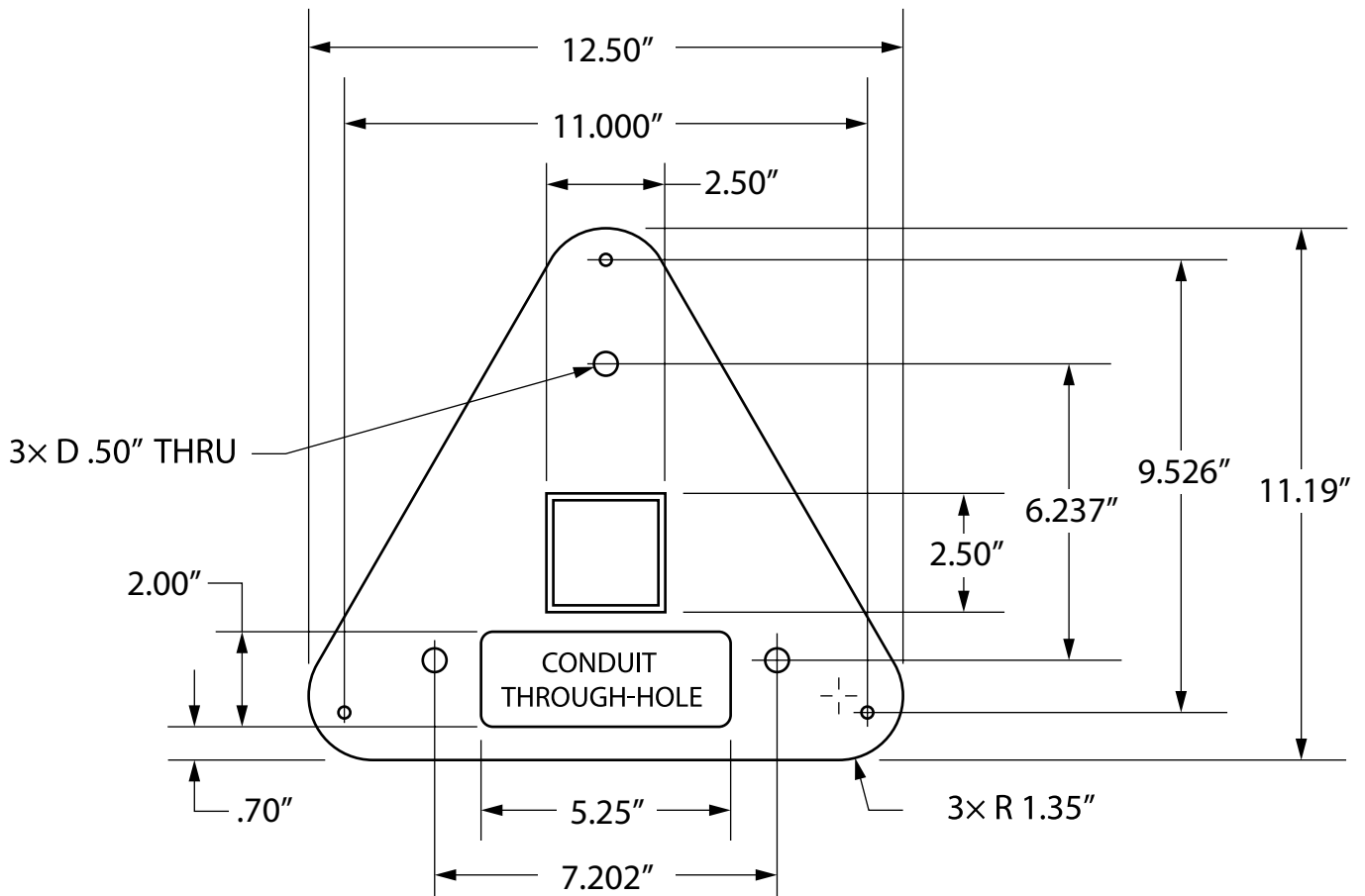



# Pre-Installation Guide

## ELECTRICAL WIRING SPECIFICATIONS

Max. Continuous Current	Typical Circuit Breaker <sup>3</sup>	Typical Wire Specs <sup>3</sup>	Typical Conduit Size <sup>3</sup>	Blink IQ Conduit Size	Notes/Assumptions
12A	15A	Two #12AWG Wires (Line) One #12AW Wire (Ground)	1/2"	1"	≤ 150 ft. One-Way Distance ≤ 3% Voltage Drop
16A	20A	Two #10AWG Wires (Line) One #8AW Wire (Ground)	3/4"	1"	≤ 150 ft. One-Way Distance ≤ 3% Voltage Drop
24A	30A	Two #8AWG Wires (Line) One #10AW Wire (Ground)	3/4"	1"	≤ 150 ft. One-Way Distance ≤ 3% Voltage Drop
32A	40A	Two #8AWG Wires (Line) One #10AW Wire (Ground)	3/4"	1"	≤ 150 ft. One-Way Distance ≤ 3% Voltage Drop
40A	50A	Two #6AWG Wires (Line) One #8AW Wire (Ground)	3/4"	1"	≤ 150 ft. One-Way Distance ≤ 3% Voltage Drop
64A	80A	Two #4AWG Wires (Line) One #8AW Wire (Ground)	1"	1"	≤ 150 ft. One-Way Distance ≤ 3% Voltage Drop
72A	90A	Two #3AWG Wires (Line) One #8AW Wire (Ground)	1"	1"	≤ 150 ft. One-Way Distance ≤ 3% Voltage Drop
80A	100A	Two #2AWG Wires (Line) One #8AW Wire (Ground)	1"	1"	≤ 150 ft. One-Way Distance ≤ 3% Voltage Drop

<sup>3</sup>Consult with a licensed contractor, licensed electrician, or trained installation expert to ensure compliance with local building codes and safety standards.

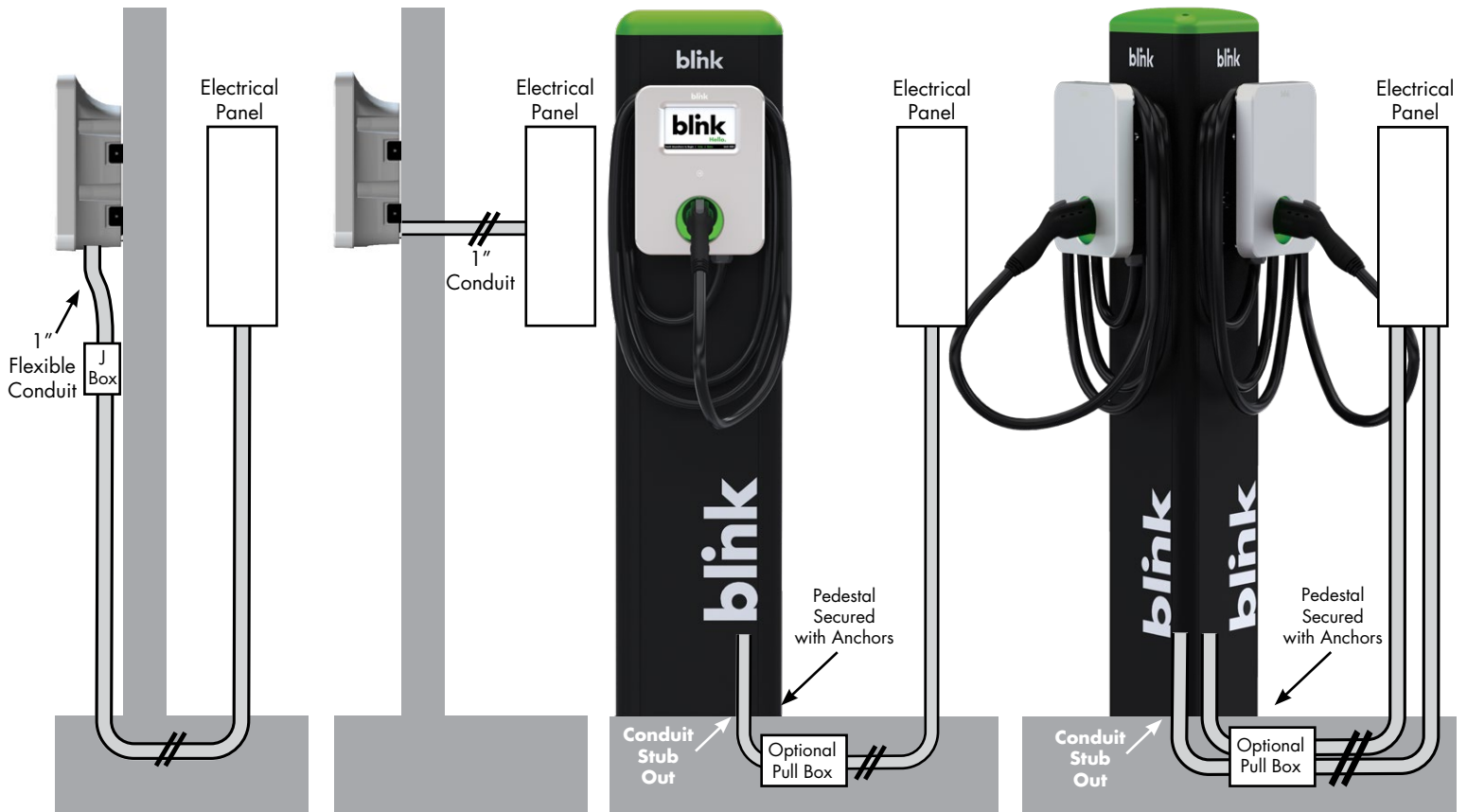

**Wall Mount  
Option 1**

**Wall Mount  
Option 2**

**Rectangular Pedestal  
Mount, Single**

**Triangular Pedestal  
Mount, Dual**

**blink**

BlinkCharging.com  
(888) 998.2546