

Tire Changer Accessories



Revolution™ accessories

The standard Revolution tire changer comes equipped to handle virtually all tire and wheel combinations.

A	RP6-3784	Paste
B	RP6-1506	Paste brush
C	69-1394-2	Pin protector (2)
D	221-759-2	Valve core remover
E	221-659-2	Bead starting tool
F	RP11-2020688	Valve puller
G	192-233-1	In-between cone (2)
H	192-225-1	Small polymer cone (2)
I	192-226-1	Double-sided polymer cone (2)
J	111-154-1	Spare roller
K	179-15-2	Glasses
L	221-713-2	Polymer mount head (2)
M	69-1392-2	Rubber platten cover (2)



The following options can be used to enhance serviceability of specialized applications.



Flange plate kit 20-3158-1

Ideal for plastic clad wheels or reverse wheels where maximum protection is needed. Maximum diameter 240 mm.

Standard with TCR1S



Camera kit 20-2945-1

Camera kit records tire changing. Can be used to verify correct usage and training.

Suitable for TCR1 (not S)



Dual wheel adaptor 20-2964-1

Optional adaptor adds clamping capability for dual wheels, 19.5 in. wheels and other wheels with large center holes.

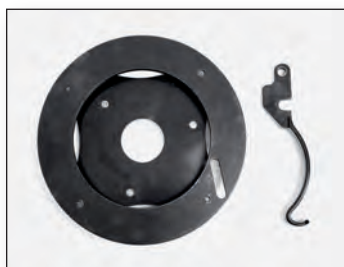

Thick bead kit 20-3160-1

Wider hook for thicker beads. Suitable for skid steer, load range G-H-J-tires. Plus, reverse wheel plate for 19.5- and 17.5-in. rims.



TCR1S

TCA-series accessories

The standard Auto34S tire changer comes equipped to handle virtually all common tire and wheel combinations.

A	RP6-G1000A80	Quick clamp
B	RP6-710090480	Pin protector (2)
C	RP6-710012940	Pin extension
D	145-341-2	Air chuck
E	RP6-710090730	Traction bar
F	148-133-2	Lubrication oil
G	179-15-2	Glasses
H	221-659-2	Bead starting tool
I	RP6-3784	Paste
J	RP6-1506	Paste brush
K	RP6-710013421	Support plate cover (2)
L	RP6-710014120	Toolhead (2)
M	RP6-1157	Two-sided cone
N	RP6-G1000A86	Mirror



The following options can be used to enhance serviceability of specialized applications.



Flange plate kit RP6-G1000A87

Optional kit is ideal for plastic-clad wheels or reverse wheels where maximum protection is needed.

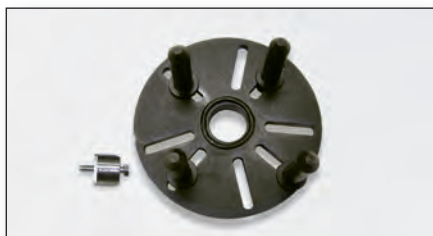

Basic flange plate RP6-G1000A123

Optional kit handles plastic-clad wheels without the need of reverse applications.



Contoured Press Head

Bead press head for special applications. Required by BMW.

TCA34S use **RP6-G1000A111** (pictured)
TCA34 use **RP6-G1000A94**



PAX® tire system kit RP6-G1000A73

Optional kit for servicing Michelin® PAX® systems. (TCA34S & TCA34 only)

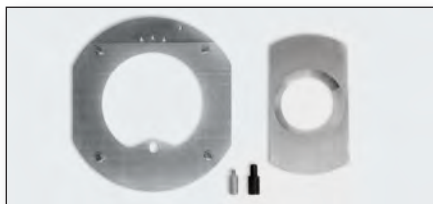

19.5 inch adaptor – 20-2341-1

Adds clamping capability for 19.5 in. wheels with large center holes.



TCA34S

TC-series standard accessories

Each Hunter TC-series tire changer includes a variety of accessories to help service a wide range of tire and wheel combinations.

			TC3715	TC3700	TC3315	TC3305	TC3300
A	20-2502-1	Bead press arm	✓		✓		
B	20-2565-1	Plus arm device				✓	
C	RP6-G1000A80	Quick clamp	✓	✓	✓	✓	✓
D	179-15-2	Safety glasses	✓	✓	✓	✓	✓
E	148-133-2	Lubrication oil	✓	✓	✓	✓	✓
F	RP6-3784	Mounting paste	✓	✓	✓	✓	✓
G	RP6-1506	Paste brush	✓	✓	✓	✓	✓
H	RP6-710090730	Traction bar					
I	RP6-G1000A67	28" bead depressor tail w/ traction bar	✓	✓			
J	RP6-1157	Two-sided cone	✓	✓			
K	RP6-G1000A7	Mechanical bead roller	✓	✓			
L	RP6-710013421	Support plate cover (2)	✓	✓	✓	✓	✓
M	RP6-G800A11	Shovel protector (2)	✓	✓	✓	✓	✓
N	221-675-2	Extra mount head	✓	✓	✓	✓	✓
O	RP6-710090480	Pin protector (2)	✓	✓	✓	✓	✓
P	RP6-710012940	Drive pin extension	✓	✓	✓	✓	✓
Q	RP6-0326	Bead protector sleeve	✓	✓			
R	145-341-2	Air chuck	✓	✓	✓	✓	✓
S	RP6-G1000A11	"HM" bead lever	✓	✓			



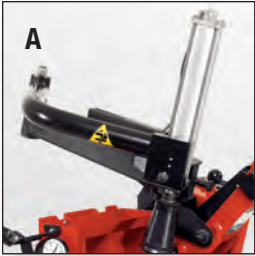

Bead press arm – 20-2502-1

Suitable for TC3700, TC3510, TC3500 and TC3300 series tire changers.

Standard on TC3715.



Plus arm device – 20-2565-1

Suitable for TC3300 model tire changers.

Not compatible with TC3250.

May not be combined with bead press arm [20-2502-1].

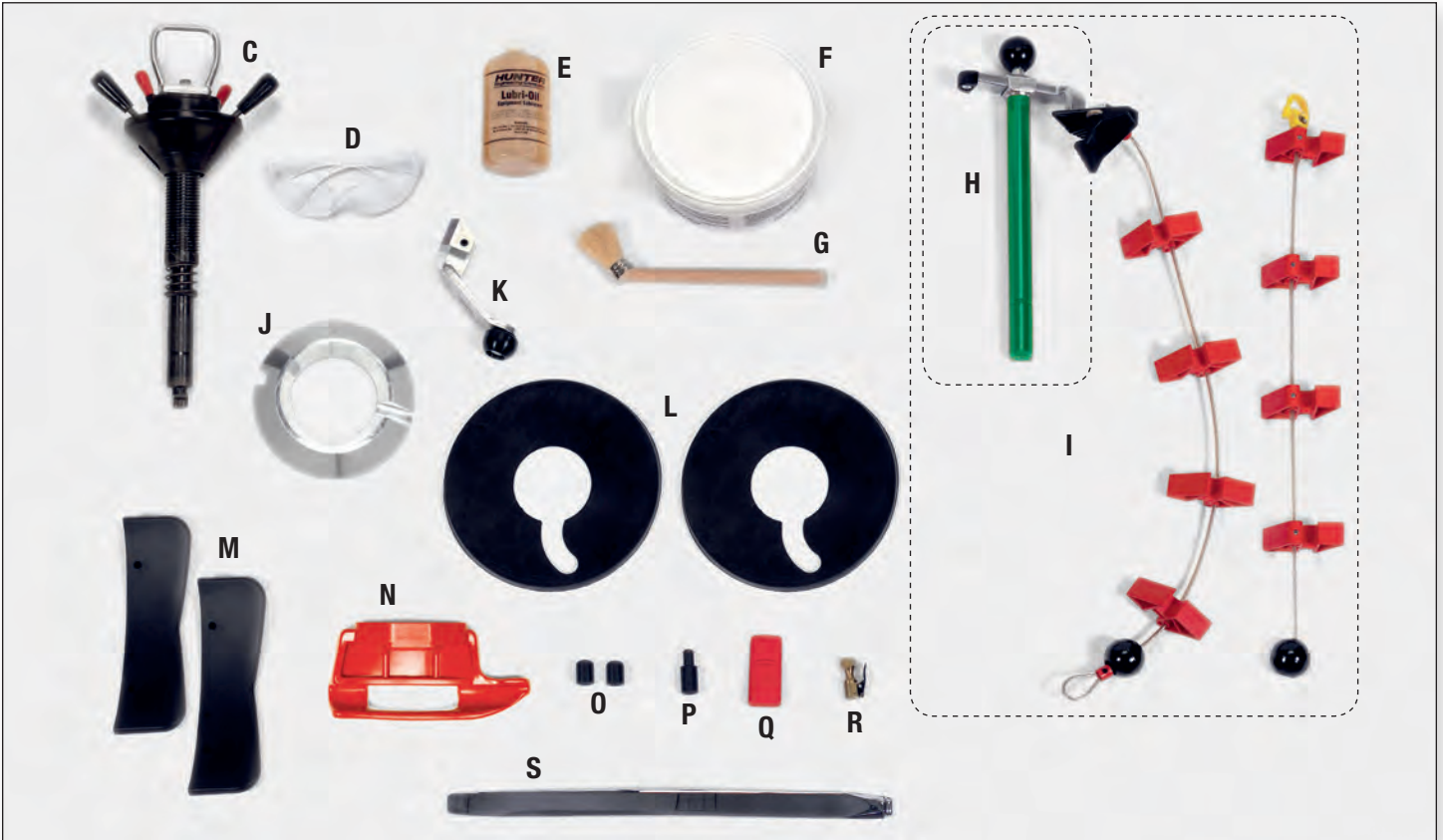

TC3305



TC3300

TC-series accessories

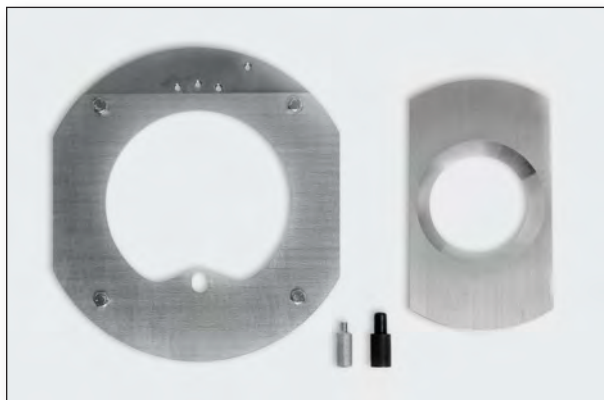

**19.5-inch truck center cone adaptor kit
20-2341-1**

Adapts large center-bore wheels to center-clamp tire changers (TC3700, TC3300, TCA34, TCA28).



**Rubber protection plate for center-clamp
tire changers – RP6-710013421**

Soft, rubber plate protects rim when servicing reverse wheels. Intended to be removed when not servicing reverse wheels.



**Flange plate
for center-clamp
tire changers
RP6-G1000A87**

Useful for plastic-faced wheels and/or reverse wheels where maximum finish protection is needed. Max diameter 230mm.



**Flange plates
for clad wheels
RP6-G1000A123**

For plastic-faced wheels only.



**Long flange plate pins
RP6-G1000A102**

Optional pins are longer, allowing servicing of reverse wheels with extra deep spokes. For use with Hunter center-clamp flange plate [RP6-G1000A87].



Short drive pin – 135-486-2

Useful when servicing some reverse wheels. Also useful in combination with older [20-2341-1] 19.5 kits and GM 16 in. dually wheel service.

Standard with 19.5 in. kit [20-2341-1].



**Drive pin protectors for
center-clamp tire changers
RP6-710090480**

Plastic cap protects lug holes of reverse wheels when clamped face down.



Polymer mount head (1 ea.) – 221-675-2

Rides closer than steel designs, reducing stress to beads when demounting and mounting low-profile tires. Wear component designed to protect the tire and rim.

221-675-2-B Polymer mount heads (6 ea.)

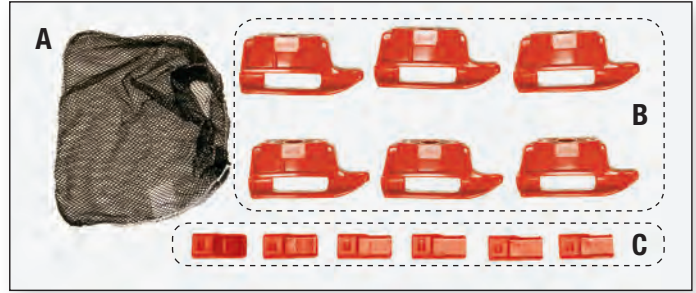

Polymer head maintenance kit – 20-1506-1

Provides convenient way to store maintenance items at the tire changer. *Kit includes:*

- A** | **166-51-2** | Nylon mesh storage bag
- B** | **221-675-2** | Polymer mount heads (6 ea.)
- C** | **RP6-0326** | Bead lever protector sleeves (6 ea.)



Rimsled & mount head kit – RP6-G1000A91K

Provides additional protection for painted or plastic-clad rims. Rimsled only fits “black” mount heads supplied in kit.

- A** | **RP6-G1000A14** | Individual mount head
- B** | **RP6-12916** | Rim protector (box of 50)



**Mounting belt kit
RP6-G1000A8**

For mounting and matching difficult ultra-low-profile and runflat tires.



**Plastic shovel protectors (1 ea.)
RP6-G800A11**

Clip-on side shovel protectors prevent damaging metal-to-metal contact when bead loosening.



Mechanical bead roller – RP6-G1000A7

Pushes the upper bead of the tire below the right hand area of the mount head keeping the tire in the proper location during mounting. Eliminates extra work to mount stiff tires.

TC-series accessories cont.



Storage bracket RP6-7900113100

For storage of the center-shaft or center support when not in use. Attaches to the storage tray by drilling two small holes.



External rubber clamping jaw for TC35XX / TC3250 (1 ea.) RP6-8659

For external clamping of reverse rims. Not compatible with first generation RP6-4177.



Shaft extender – RP6-790012540

Useful to extend the clamping shaft when used with older RP6-G1000A87 flange plates. Standard with all new flange plates.

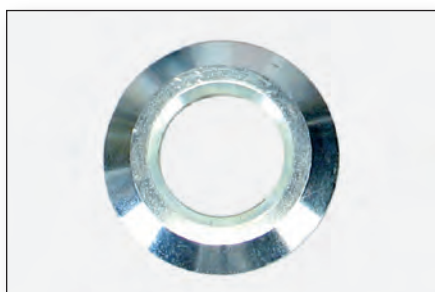

Two-sided cone for LT wheels RP6-1157

For use with the regular-sized clamping cone when the wheel hub bore is larger than the standard cone.



Cone cover, wheel hub protector RP6-1156

Protects the wheel hub bore from contact when center-clamping.



Wide toolhead – RP6-710014120

Suitable for TCA34S, TCA34 and TCA28 tire changers with serial numbers 664 and above.



Force multiplier – RP6-G1000A23

Adds leverage when seating the mount head and holding it down against the wheel.

Suitable for TC3300 and early TC3700 prior to vertically-locking mounthead.

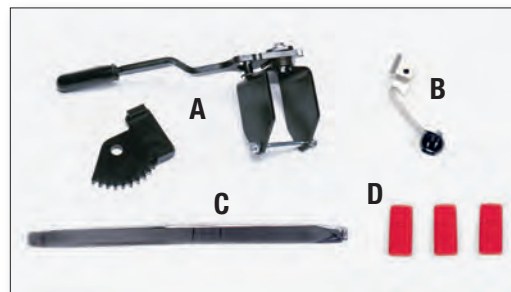

Plus kit for TC3300 – 20-2707-1

Includes:

A	RP6-G1000A23	Force multiplier
B	RP6-G1000A7	Mechanical bead roller
C	RP6-G1000A11	"HM" bead lever
D	RP6-0326	Bead lever protector sleeves (3 ea.)

PAX® tire system tools & kits



			TC3900 / TC3700	TC3500
			All generations	20-1795-1
			20-2268-1	
A	RP6-14783	PAX arm with large roller	✓	✓
B	RP6-41942	PAX arm with small roller (2)	✓	✓
C	221-684-2	Ratchet strap	✓	✓
D	RP6-8703	Brass shaft protector		✓
E	RP6-11522	Quick-disconnect shaft		✓
F	RP6-1156	Short cone rim protector		✓
G	RP6-1460	Short cone (2)		✓
H	RP6-4153	Stroke limiters	✓	✓
I	RP6-4100001	PAX bead levers (2)	✓	✓
J	RP6-7042	Plastic rim protectors (4)	✓	✓

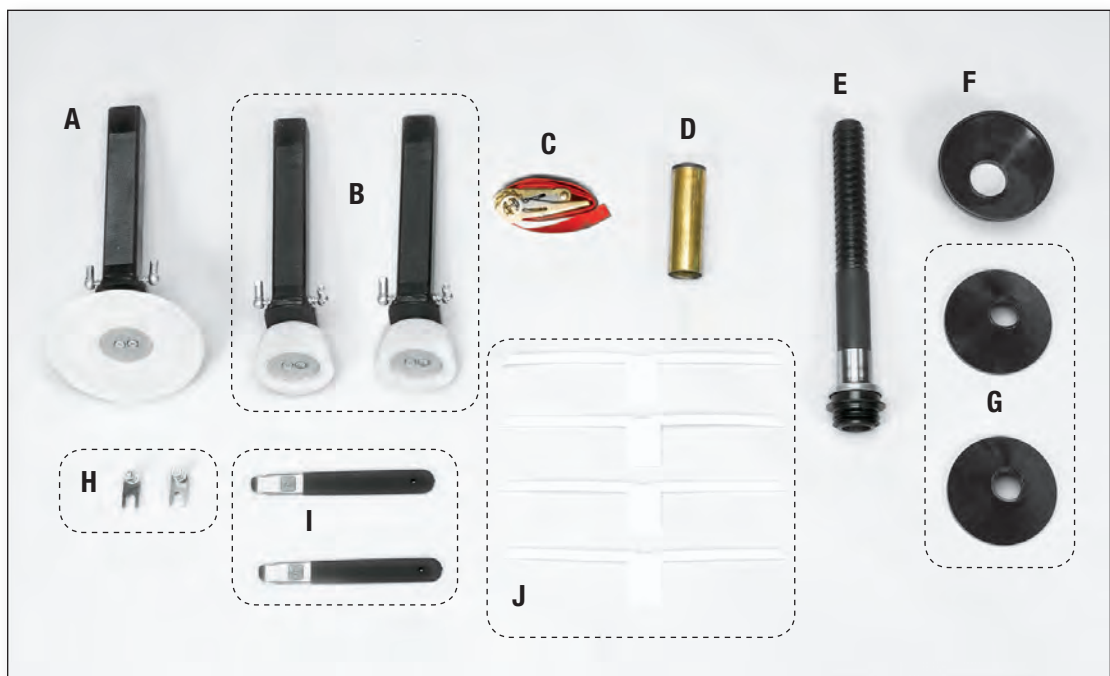

PAX upgrade kits used to upgrade early TC3500's may also require the quick-disconnect coupling bolt and center support kit [RP6-10822] to utilize the newly upgraded quick-disconnect threaded center shaft [RP6-11522] supplied in the newer PAX upgrade kits.

TCX-series standard accessories

Hunter TCX-series tire changers include a variety of accessories to help service a wide range of tire and wheel combinations.

			TCX57	TCX56	TCX53L	TCX53	TCX51L	TCX51	TCX50
A	Leverless	Leverless mount head	✓		✓		✓		
B	BPS	Bead press system w/ two roller arms & lift/disk	✓	✓	✓	✓			
C	BP	Single bead press arm					✓	✓	
D	RP11-4-403749	BP press cone					✓	✓	
E	RP11-2121350	Large pressing cone	✓	✓	✓	✓			
F	RP11-2413305	Small pressing cone	✓	✓	✓	✓			
G	RP11-2202239	Pressing cone extension	✓	✓	✓	✓			
H	RP6-3784	Mounting paste 3.5 kg	✓	✓	✓	✓	✓	✓	✓
I	RP6-1506	Applicator brush	✓	✓	✓	✓	✓	✓	✓
J	RP11-8-11100402	Jaw extender & reducer	✓	✓					
K	RP11-8-11100358	Hi-grip jaw protector	✓	✓	✓	✓	✓	✓	✓
L	145-341-2	Tire inflator/air chuck	✓	✓	✓	✓	✓	✓	✓
M	RP11-8-11400327	Bolt-on plastic head		✓		✓		✓	✓
N	RP11-5-104797	Bolt-on steel head		✓		✓		✓	
O	179-15-2	Safety goggles	✓	✓	✓	✓	✓	✓	✓
P	RP11-5-490223	Plastic shovel protector	✓	✓	✓	✓	✓	✓	✓
Q	148-133-2	Lubrication oil	✓	✓	✓	✓	✓	✓	✓
R	RP11-8-11400098	Bead lever protector sleeve	✓	✓	✓	✓	✓	✓	
S	221-659-2	Bead starting tool	✓	✓					
T	RP11-8-11400325	Leverless mount head inserts	✓		✓		✓		
U	RP11-2202106	Rim edge protector	✓	✓					
V	RP11-2020688	Valve stem puller	✓	✓					
W	221-759-2	Valve core remover	✓	✓					
X	RP11-3009516	Bead lever (standard)	✓	✓	✓	✓	✓	✓	✓
Y	RP11-8-11100369	Mount head inserts (traditional)		✓		✓		✓	





TCX53



TCX51



TCX50

Bead assistance



Bead press arm for TCX50 series 20-2833-1

- ✓ The pressing head pushes the tire into the drop-center when demounting stiff sidewall tires, greatly reducing lever effort and risk of bead damage.
- ✓ The standard press cone used with the bead press arm will press the rim onto the jaws for easier clamping of stiff tires.
- ✓ The standard bead press roller keeps stiff tires under the mount head and guides the bead.
- ✓ Lifting hook.
- ✓ Not suitable for older TCX5X5 variations.

Standard with TCX51 (E, A or H models)



PATENTED

Bead press system for TCX50 series 20-2834-1

- ✓ Uniquely centers the pressing capabilities over the center of the wheel and tire to ensure maximum service strength and rigidity.
- ✓ Provides effortless assistance with most difficult tires and custom wheels up to 26" diameter.
- ✓ Not suitable for older TCX5X5 variations.

Kit includes:

- Bead press system with stationary arm, rotating arm & bead lifting arm
- Small pressing cone **RP11-2413305**
- Large pressing cone **RP11-2121350**
- Pressing cone extension **RP11-2202239**

Standard with TCX53 (E, A or H models)

TCX-series accessories

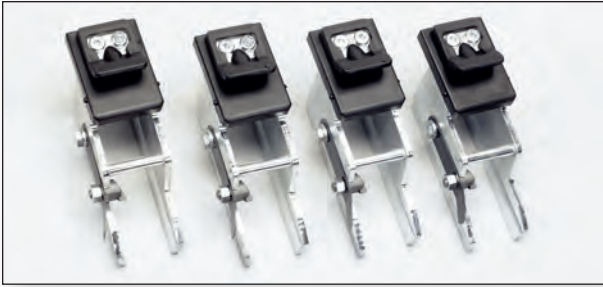

Jaw extender & reducer (4 ea.)

RP11-8-11100402

Extends range by 4 inches. Reduces range by 5 inches.

Note: For small wheel service (6-8 in.), mount head will not reach and is too large. Standard practice is to clamp with adaptors and service with spoons.



High grip jaw protectors (8 ea.)

RP11-8-11100358

Polymer jaw covers prevent metal-to-metal contact when performing external clamping.



Motorcycle adaptor

RP11-2200277

Raise the clamping jaws to clear the integrated disc brake or drive sprockets used on motorcycle wheels. Plastic-covered to prevent damage to wheel.

RP11-2309245

Individual adaptor



Harley Davidson

Wheel Adaptor

RP11-2201113

Raise clamping jaws to clear belt drive pulley and brakes used on Harley Davidson. Plastic-covered to prevent wheel damage.



Plastic shovel protectors (4 ea.)

RP11-5-490223

Clip-on side shovel protectors prevent damage when bead loosening low-profile tires on expensive alloy wheels.



Blast inflator

RP11-8-11100403

Direct bursts of compressed air to seat difficult beads

Suitable for TCX50-53 only.



Storage tray for

TCX505-535

RP11-8-11400187

One tray standard on all TCX500s. Second standard on TCX515. Each TCX500 can use up to 2 trays (two shown). Accessories available separately.

Not suitable for TCX50 series.



Storage shelf

20-2885-1

Large steel shelf system expands storage capacity.

Suitable for TCX50-53 only.

TCX-series mount heads and accessories

Plastic mount heads



NEW "Wing" plastic mount head upgrade for new tire changers – RP11-8-11400328

Includes 2 plastic heads and hardware to add rotation.

Suitable for TCX50 serial numbers higher than IKE721041 and TCX56 head kit serial numbers higher than VKI046785.



NEW "Wing" plastic mount head upgrade for older tire changers – RP11-8-11400329

Includes plastic head and all mounting hardware.

Suitable for TCX50 serial numbers lower than IKE721041 and TCX56 head kit serial numbers lower than VKI046785. Also suitable for all older TCX565, 550, 5x5 and 500 tire changers.



NEW

"Wing" plastic mount head
RP11-8-11400327



**Plastic mount head
RP11-8314813**

Old mount head fits all TCX-series tire changers

Leverless mount head accessories

For V1 & V2 heads



Leverless mount head inserts
(10 ea.) – RP11-8-11400293



Right side plastic protectors
for leverless mount heads
(10 ea.) – 20-2684-3

NEW For V3 heads



Leverless mount head inserts
(10 ea.) – RP11-8-11400325



Single leverless
mount head
right-side insert
RP11-8-1110326S

For V1, V2 & V3 heads



Rear plastic protectors
(10 ea.) – 20-2685-3



Replacement screw
for protector
(3 required)
RP11-2-03438

Steel mount heads & accessories



Steel mount head (1 ea.) – RP11-5-104797

Replacement steel mount head. Current "slim" design fits all models and generations.



Steel mount head (1 ea.) – RP11-5-400439

Large-knob legacy design. Fits all models and generations.

Plastic protectors for new steel mount heads (10 ea.)

RP11-8-11100369

Polymer inserts for new TCX-series steel mounting head (RP11-5-104797) shown above.



Plastic protector kit for old steel mount heads (10 ea.)

RP11-8-11400096

For use with old TCX-series steel mounting head (RP11-5-400439) shown above.



Plastic protector for new steel mount heads (1 ea.)

RP11-8-1110385S

For use with new TCX-series steel mounting head (RP11-5-104797) shown above.



Single front plastic protector for old steel mount heads (1 ea.)

RP11-8-11100303S

Polymer insert for old TCX-series steel mounting head (RP11-5-400439) shown above.



Mechanical bead roller for TCX505-550 standard heads RP11-5-400900

Optional feature used to mount stiff low-profile tires. Eliminates extra work to mount stiff tires.

Not needed when using new "wing style" mount heads.

Use **RP11-8-11100327** for leverless heads.

Wheel lift systems

Servicing large, heavy SUV, light-truck and custom wheels requires extra effort. The optional pneumatic wheel lift helps prevent potential injuries and fatigue from lifting heavy wheels into place.

The pedal-controlled wheel lift quickly raises the wheel, leaving the technician's hands free to control and position it on the tire changer clamping system.

A wheel lift can be ordered with newly purchased tire changer or separately as a retrofit kit. See the chart below for part numbers.

Base tire changer	Model number with wheel lift included	Wheel lift part number if ordered separately
TCA34	TCA34W	20-2236-1
TC3900	TC3900W	20-2944-1
TC3700	TC3700W	20-2944-1
TC3715	TC3715W	20-2944-1
TCX575	TCX575W	20-2044-1
TCX565	TCX565W	20-2044-1
TCX550EBPS	TCX550EWBPS	20-2044-1
TCX57	TCX57W	20-2045-1
TCX56	TCX56W	20-2045-1
TCX53E	TCX53EW	20-2045-1
Other TCX50-500	—	20-2045-1



TC3715SS shown with optional 20-2944-1 wheel lift system



TCX57 shown with optional 20-2045-1 wheel lift system



TCA34 shown with optional 20-2236-1 wheel lift system

Integrated wheel lifts boost productivity and help prevent injury and fatigue



The Hunter wheel lift system makes servicing large wheels easy! Roll the wheel on the lift...

... activate the automated lifting device by pressing the lift foot pedal.

The lift automatically raises the wheel to an ergonomic height. Simply position wheel as needed. It's that easy!



Heavy-duty tire changer standard accessories

			TCX625HD	TCX625PHD	TCX640HD
A	RP11-8-12100040	Wheel ramp (2 included)		✓	
B	RP11-12100039	Pocket V cover		✓	
C	RP11-2105943	Tube tire bead guide			✓
D	RP11-3006365	Standard lever			✓
E	RP11-2105954	Truck bead lever	✓	✓	✓
F	RP11-8-12100181	Mounting lever (steel & ALU heads)		✓	
G	RP11-2200041	Alloy wheel clamp jaws (4)			✓
H	RP11-801254494	Aluminum jaw covers (4)		✓	
I	RP11-2005957	Steel wheel clamp	✓	✓	✓
J	RP11-2306808	Alloy wheel clamp	✓	✓	✓
K	RP6-3784	Mounting paste	✓	✓	✓
L	RP6-1506	Brush	✓	✓	✓

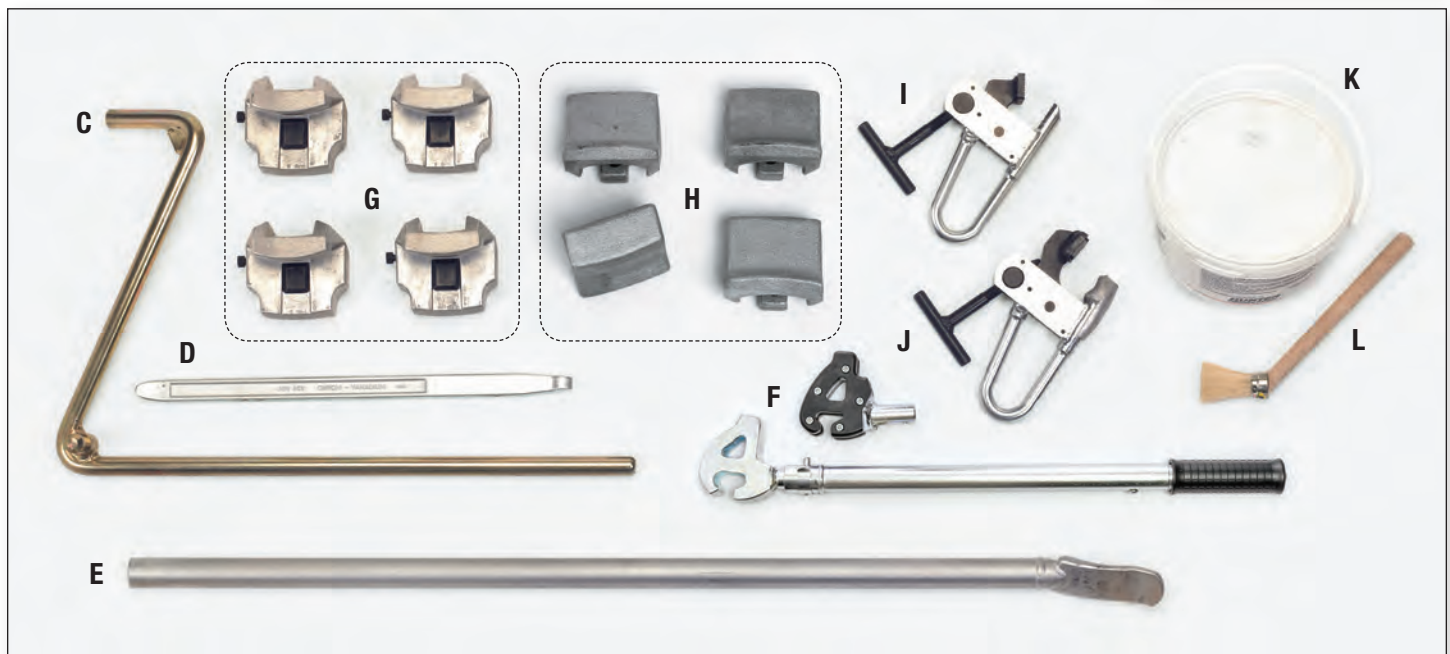
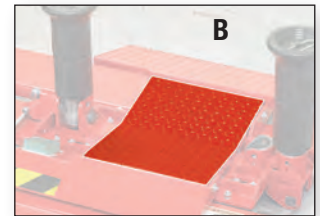
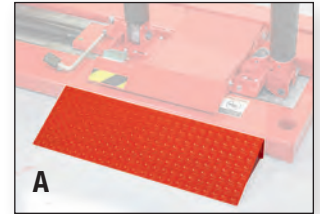

TCX625HD



TCX640HD

Heavy-duty tire changer optional accessories

TCX625HD



Centerless wheel jaw adaptors
RP11-8-12100176

Service centerless wheels by securely gripping the inboard edge.



Aluminum jaw covers
RP11-801254494

Prevents center-bore damage on aluminum wheels.

Standard with TCX625PHD



Mounting lever
RP11-8-12100181

Speeds outside bead mounting.

Includes steel wheel and ALU wheel heads.

Standard with TCX625PHD

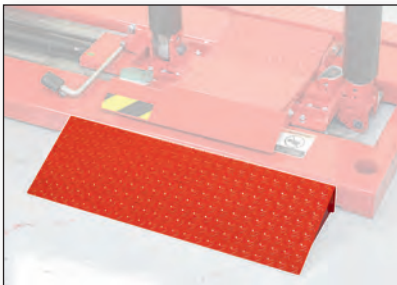

Single ramp
RP11-8-12100040

Ease rolling tire onto changer.

One included

Standard with TCX625PHD

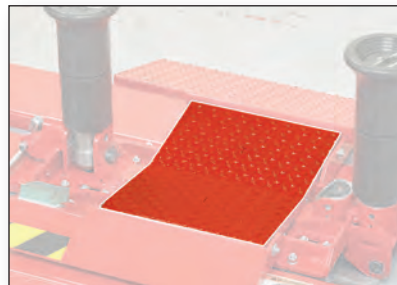

Pocket V cover
RP11-12100039

Dress up cover for carriage.

Standard with TCX625PHD

TCX640HD



Tubeless roller
RP11-2306040

Eases bead loosening, mounting and demounting of tubeless truck and bus tires.



Drop-center clamp
RP11-801251904

For skidder and similar type tires



Self-centering tulip chuck extensions (4 ea.)
RP11-8-12100155

Expands clamping size capacity to 56 inches.

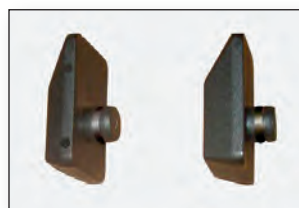

Alloy jaws insert
RP11-8-12100172

For use on units with serial number iic735988 or greater.

Universal accessories



A. High-performance bead lever "HM" RP6-G1000A11

Patented, high-performance bead lever dramatically reduces servicing effort. A must for servicing low-profile tires.

B. Bead lever protector sleeve – RP6-0326

Protects wheel flange by allowing the bead lever to slip out of the tire instead of being dragged against the rim during demounting.

RP6-0326-B Box of 10



A. Traditional flat design bead lever – RP11-3009516

For demounting tires on conventional tire changers.

B. Bead lever sleeve protectors (4 ea.) RP11-8-11400098

Protects wheel flange by allowing the bead lever to slip out of the tire instead of being dragged against the rim during demounting.

For use with RP11-3009516 Bead Lever Tool

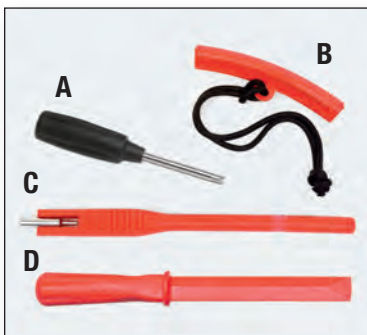

A. Valve core remover 221-759-2

B. Rim edge protector RP11-2202106

C. Valve stem puller RP11-2020688

D. Bead starting tool 221-659-2

Bead depressor tails helps position low-profile tires into drop-center for mounting & demounting

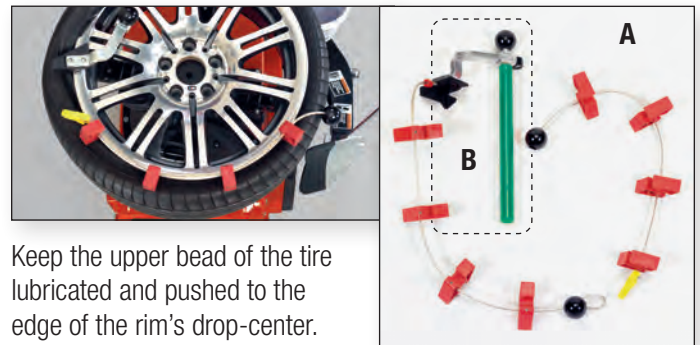

Keep the upper bead of the tire lubricated and pushed to the edge of the rim's drop-center.

A. 28-in. bead depressor tail with traction bar RP6-G1000A67

Aids in locking tire to rim and pushing low-profile tires down into drop center for mounting. Services up to 28 in. diameter rims.

B. Traction bar – RP6-710090730

Traction bar only. Used to lock tire to rim.

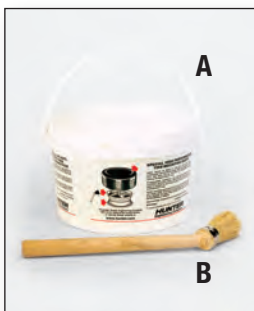

A. Mounting paste (3.5 kg) – RP6-3784

Eases mounting of stiff low-profile tires. Aids in faster bead sealing during inflation. High-performance mounting paste is premixed to prevent incorrect mixing of water to liquid concentrates.

RP6-3784-B = 8 Buckets

RP6-3784-BP = 64 Buckets [1 pallet]

B. Brush, angled applicator – RP6-1506

Provides proper application of mounting paste. Angled to allow easy access to the "toe area" of the bead most commonly damaged during mounting.



Lubri-Oil air equipment lubrication 148-133-2

Lubri-Oil will not emulsify in water. When the lubricator becomes contaminated with water overflow from the regulator, the oil will separate. Available in 16-oz bottles. Twelve (12) to a case when ordered in quantity. Lubri-Oil weight is ISO32.



Drop-center mounting clamp RP6-70210E

Helps position the bead into the drop-center. Not for extreme positive offset, flat-faced rims or soft-line flanges.

Alternative tools: RP6-1572, RP6-7290



ROTUNDA

Contact your
Field Service Engineer

or

Rotunda Area Sales Manager

1.800.ROTUNDA

www.OneRotunda.com