

The logo features the text 'PFM X9' in a bold, sans-serif font. The 'P' and 'F' are white, while the 'M' is white with a yellow diagonal stripe. The 'X' is white with a yellow diagonal stripe. The '9' is white with a yellow diagonal stripe. Below this, the words 'TECHNICAL MANUAL' are written in a smaller, white, sans-serif font.

PFM X9
TECHNICAL MANUAL

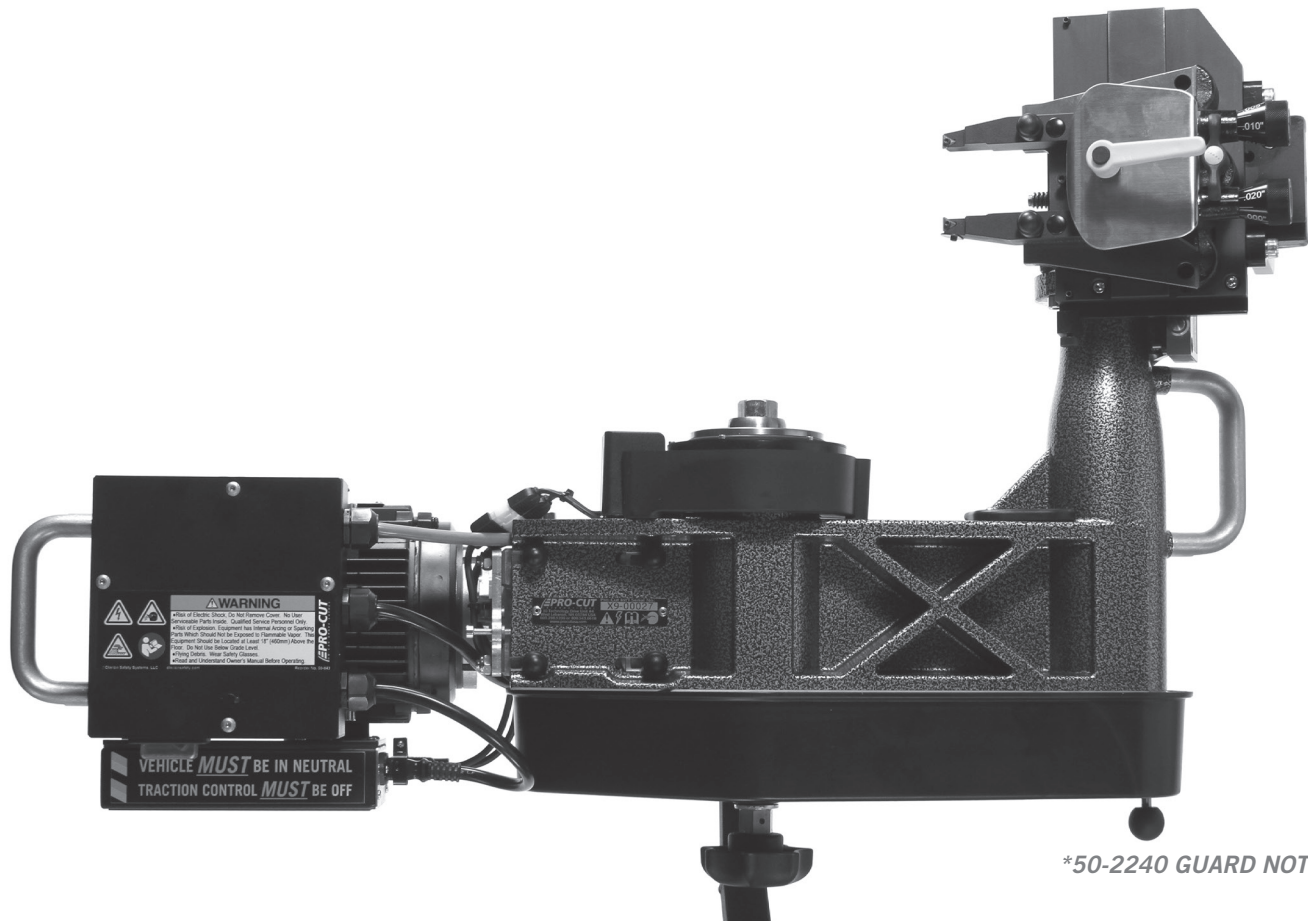

WARNING
Risks of Electric Shock. Do Not Remove Cover. No User
Adjustment Permitted. Qualified Service Personnel Only.
Risks of Explosion. Equipment Has Internal Arcing or Sparking
Parts Which Could Be Ignited by Synchronous Motor. This
Equipment Should Be Located at Least 1' (300mm) Above the
Floor. Do Not Use Safety Cables.
Wiring Defects. Wear Safety Glasses.
Read and Understand Owner's Manual Before Operating.
©2010 Pro-Cut Machine, LLC
www.pro-cut.com
Pro-Cut

VEHICLE **MUST** BE IN NEUTRAL
TRACTION CONTROL **MUST** BE OFF

**50-2240 GUARD NOT SHOWN*



X9

TECHNICAL MANUAL

P · 800.543.6618
F · 603.298.8404
info@procutusa.com
www.procutusa.com

OUR MISSION

Pro-Cut International is dedicated to providing our customers with the most advanced, precise, and profitable tools for brake repair. We have worked with, learned from and solved problems for people at all levels of the brake repair business - from the largest auto manufacturers and national service chains to one-bay, one-man operations. It is a business our entire staff lives, eats, and breathes. We welcome you to our table and look forward to working with you to improve your brake service business.

Limited Warranty

This warranty extends to the original owner of the the equipment. Pro-Cut International warranties this equipment against defects in materials or workmanship as follows.

Labor

For the period of one (1) years from the original date of purchase, if we determine that the equipment is defective subject to the limitations of this warranty, we will replace it at not charge for labor. Pro-Cut International warrants any such work done against defects in materials or workmanship for the remaining portion of the original warranty period.

Parts

For the period of one (1) years from the original date of purchase, we will supply, at no charge, new or rebuilt replacement parts in exchange for parts we determine are defective subject to the limitations of this warranty. Pro-Cut International warranties any such replacement parts against defects in materials or workmanship for the remaining portion of the original warranty period.

What Your Warranty Does Not Cover

This warranty does not apply to damage due directly to misuse, abuse, negligence or lack of maintenance.

CONTENTS

4	Pro-Cut Mission	48	50-1148 Gage Pick Up Module
7	Safety and Warning Information	50	G2X Calibration
8	Introduction	53	G2X Troubleshooting
10	Lateral Run-out Defined	
12	X9 Lathe Overview	54	GYR Technical Supplement
14	Lathe Setup	56	GYR Component Overview
16	Vehicle Preparation	58	Setting up your GYR
18	Lathe Preparation: Checking Cutting Tips	60	GYR Service Corridor Concept
19	Machining Rotors: A 4 Step Guide	67	Customer Vehicle and Management Reports
	Step 1: Mount the Adapter	69	GYR Troubleshooting
	Step 2: Set Up the Lathe	72	Adapter Guide
	Step 3: Adjust for Lateral Run-out	74-85	X9 Parts Diagrams
	Step 4: Make the Cut		
27	Machining the Opposite Side		X9 Lathe Body
28	Vehicle Reassembly		50-220 Cutting Head
29	Maintenance		50-139 Bevel Gear Box
30	Troubleshooting: Assuring a Smooth Finish		50-2195 Trolley
33	Troubleshooting: Lateral Run-out Adjustment		50-1148 Gage Pick Up Module
34	Troubleshooting: Raising or Lowering the Acceptance Number		50-1158 Computer Box
36	DRO Compensation Instructions		50-1200 Cutting Head
.....			
40	G2X Technical Supplement		50-1206 Slide Sensor
42	G2X Component Overview		50-2240 Spindle Guard
44	50-1200 Cutting Head		50-143 Slide Assembly
47	50-1206 Slide Sensor		50-1360 GYR Command Center
			50-1902 Motor and Gear Box Assembly
		86	Maintenance Schedule

IMPORTANT SAFETY INSTRUCTIONS

The X9 Rotor Matching System is a precision instrument which requires close attention while in operation. It will provide many years of service if it is operated safely. Basic Safety precautions should always be followed, including the following:

1. Read all instructions
2. Care must be taken as burns can occur from touching hot parts.
3. Do not operate equipment with a damaged cord or if the equipment has been dropped or damaged - until it has been examined by a qualified service person.
4. Do not let a cord hang over the edge of the table, bench, counter or come in contact with hot manifolds or moving fan blades.
5. If an extension cord is necessary, a cord with a current rating equal to or more than that of the equipment should be used. Cords rated for less current than the equipment may overheat. Care should be taken to arrange the cord so that it will not be tripped over or pulled
6. Always unplug equipment from electrical outlets when not in use. Never use the cord to pull the plug from the outlet. Grasp the plug and pull to disconnect.
7. Let equipment cool completely before putting away. Loop cord loosely around equipment when storing.
8. To reduce the risk of fire, do not operate equipment in the vicinity of open containers of flammable liquids (gasoline).
9. Adequate ventilation should be provided when working on operating internal combustion engines.
10. Keep hair, loose clothing, fingers, and all parts of the body away from moving parts.
11. To reduce the risk of electric shock, do not use on wet surfaces or expose to rain.
12. Use only as described in this manual. Use only manufacturer's recommended attachments.
13. ***ALWAYS WEAR SAFETY GLASSES.*** Everyday eyeglasses only have impact resistant lenses. *THEY ARE NOT SAFETY GLASSES.*

SAVE THESE INSTRUCTIONS

INTRODUCTION

WELCOME TO THE PRO-CUT TEAM.

Congratulations on your purchase of the **PRO-CUT X9 DRO**, the world's fastest and most accurate computerized on-car brake lathe.

For many years, on-car lathes were used only for rotors that were difficult to remove. Due to current trends, virtually all auto manufacturers now require or recommend the use of on-car technology to match every rotor to every hub. By matching a rotor to the hub, the chance of a vehicle returning for a lateral run-out induced brake pedal pulsation is virtually eliminated. There is simply no better way to refinish and match a rotor than with the patented X9 ROTOR MATCHING SYSTEM.

The following pages are designed to guide you through set-up, operation, and maintenance of your lathe. We also recommend that you view the enclosed training video.

If you have any questions along the way, please call us. Our technical support team is standing by from 8 a.m. to 5 p.m. Eastern time. Or browse our website for technical information and tips: www.procutusa.com.

YOUR LATHE PACKAGE

Every Pro-Cut X9 DRO Lathe Package comes complete, ready to assemble and use. Setup and training is included by a local, certified Pro-Cut Rep. Please contact Pro-Cut at 800-543-6618 immediately if you have not already made arrangements for on-site training. Here's what's included in a standard lathe package:

Adapter Packages 4 to 8 adapter packages

50-2095	I-Base Disc-Lock Trolley	50-246	Spacer
50-220	Speed-Lock Cutting Head	50-703	Chip Deflector / Silencer, Standard
Accessory Kit Containing:		50-729	Brake Specification Guide
30-791	Four Wheel Drive Spacer	50-742	Cutting Inserts, Box of 10
37-034	(2) S-Hooks	50-752	Lathe Cover
50-046	Nose Cone Extension	50-754	Chip Deflector / Silencer, Thick
50-179	Nut & Bolt Kit		

LATERAL Run-out leads to ...
THICKNESS VARIATION which results in ...
BRAKE PEDAL PULSATION.

Brake pedal pulsation is most often the result of thickness variation in the brake rotor. Thickness variation is the technical term for a rotor that is not uniformly thick. New rotors are uniformly thick, and stop the vehicle smoothly. But thickness variation can develop over time and eventually lead to brake pedal pulsation.

How does thickness variation develop? Through lateral run-out in the face of the rotor. Lateral run-out is the technical term for “wobble”, and is a measurement of how much the surface of the disc wobbles from side to side as it rotates .

A rotor with lateral run-out will not wear evenly, and uneven wear increases over time. As the vehicle moves down the road with the brakes relaxed, the rotor will brush each pad once per revolution, resulting in a thin spot on the rotor.

Since vehicle hubs often have lateral run-out due to stacked component tolerances, a new or newly machined rotor will often exhibit excessive lateral run-out as it turns on the hub. Most manufacturers require rotor run-out to be below 0.002”. The X9 Rotor Matching System allows you to match every rotor to the hub on which it turns. The on-board computer delivers a precise alignment between the lathe axis and the hub axis, thereby guaranteeing that a Pro-Cut machined rotor will have less than 0.001” lateral run-out every time.

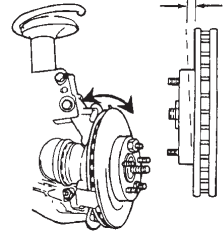

By match-matching the rotor to the hub assembly on which it resides, lateral run-out will be reduced to below OEM specs every time!

Lathe Overview

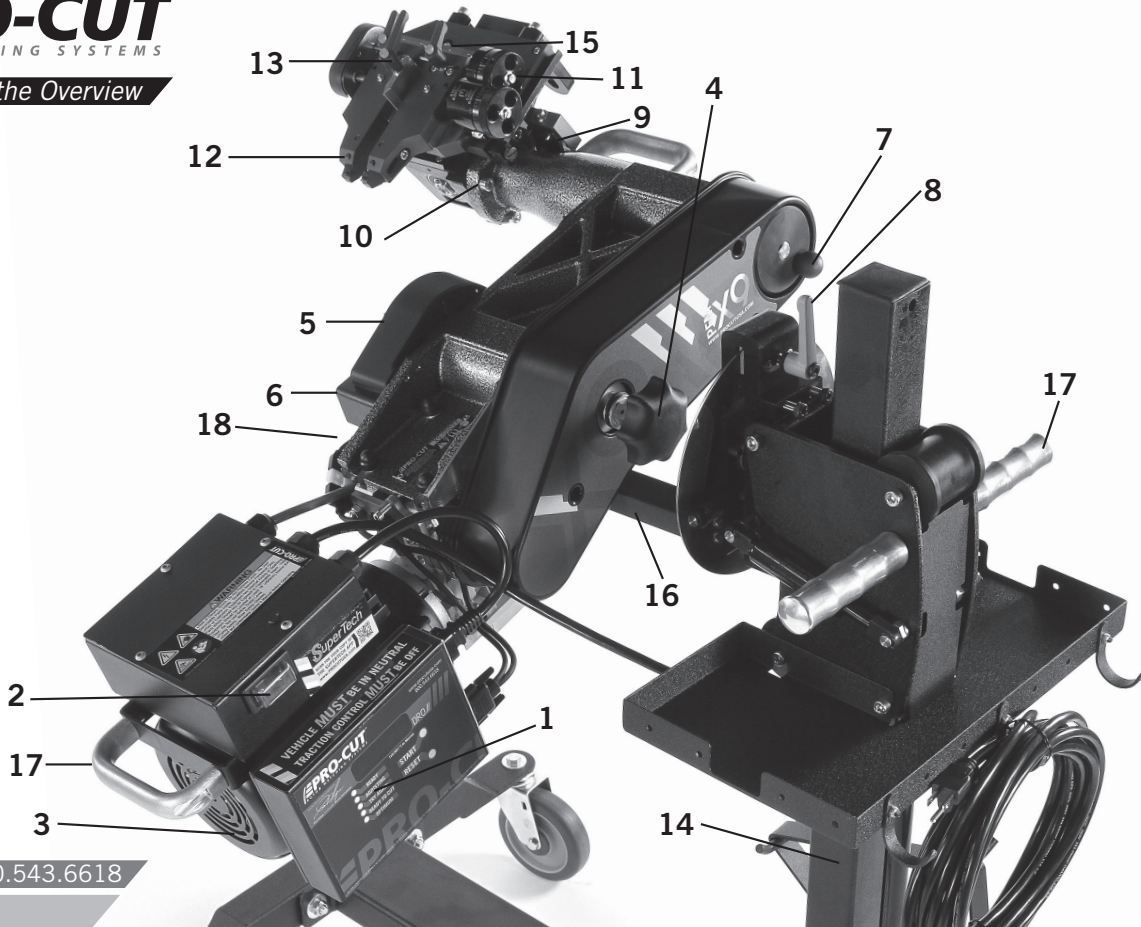

COMPONENTS

1. X9 Computer Box
2. On/Off Switch
3. 1 hp Motor
4. Draw Bar Knob
5. Adjustment Flange (*obscured*)
6. Adjustment Solenoid
7. Feed Engagement Knob (*obscured*)
8. Disc-Lock Lever
9. Automatic Shut-off Switch
10. Automatic Shut-off Cam
11. Cut Depth Adjustment Dials
12. Cutting Tips/Inserts
13. Tool Arm Lock Knob
14. Trolley
15. Cutting Head lateral Lock Knob
16. Lathe Mounting Bar
17. Lathe Handles
18. Trolley Receiver Arm (*obscured*)

NOTE* 50-2240 GUARD NOT SHOWN

Before you begin setting up, check contents against the parts diagram enclosed in the lathe package. If you are missing any parts, call Pro-Cut immediately.

Cutting Edge Tip

Assemble the trolley completely then get assistance from another person to mount the lathe on the trolley.

ASSEMBLE THE TROLLEY

Open the trolley box and check contents against the parts diagram . If you are missing any parts, call Pro-Cut immediately. Proceed with assembly, following the instructions enclosed in the box.

MOUNT THE LATHE TO THE TROLLEY

Once the trolley is assembled you will need to mount the lathe to the trolley. Locate lathe arm on trolley so that lathe will be in upright horizontal position when it is installed, then lock the disc-lock lever firmly.

- 1) Remove the lathe body from the shipping pallet and install mounting studs under lathe in two threaded holes the pallet bolts were removed from.
- 2) Find another person to help lift the lathe using the handles on either end, and insert the lathe mounting studs into trolley arm. Secure with two nuts (36-001B) and flat washers (37-108).
- 3) Assemble Guard to Lathe if so equipped. See Page 48 for assembly drawing of Guard 50-1730. Guard 50-1730 is mandatory in the Province of Quebec.

VEHICLE PREPARATION

Before lifting the vehicle, the front wheels should be straight and the parking brake should be off, with the transmission in neutral.

1. Raise the vehicle according to the lift manufacturer's instructions. Raise until the wheel hub is about belt level.
2. Check wheel bearings for damage or excessive play. If this or any other wheel service is required, it should be performed before match-machining the rotors as loose or damaged bearings will keep the lathe from doing the most accurate job possible.
3. Remove the wheels. Remove the brake calipers and suspend them out of the way of moving parts such as half shafts and CV joints using the yellow S-hooks provided (pn 37-034K). Be sure to remove all wheels that may turn when the lathe is turned on.
4. If the rotor is free on the hub, mark and remove it in order to assess the mating surface. Use a ScotchBrite™ type wheel on a die grinder, or other suitable wheel hub cleaning tool to remove rust or debris. Clean all material from the mounting area.
5. The rotor on the side of the vehicle that is not to be machined should be marked and removed if it is free on the hub or secured with at least 2 lug nuts. Match marking the rotors to the hub is very important.
6. Use a micrometer to measure rotor thickness and determine how much material may be removed from the rotor by comparing to brake spec guide provided. Visually inspect for deep rust or grooves. This inspection will help determine the depth of the cut.

NOTE: Remember to index mark rotors before removing them so you can be sure they are returned to the same positions on the hub.

It is important to start on the proper side. The Pro-Cut mounts directly to the hub of the vehicle. With the lathe right-side up (FIG:1) the cutting head is to the right of the hub as you face the vehicle wheel well. When machining a rotor, the cutting head is most often positioned where the caliper rides. On a vehicle where the calipers ride in front of the hub, always start on the passenger side. If the caliper rides to the rear of the hub, begin on the driver's side.

When you flip the lathe to machine the opposite side of the vehicle (FIG:2), no inboard / outboard cutting head adjustments are required since they were made in the upright position.

NOTE

The Pro-Cut X9 machines both front and rear rotors. The lathe's operations do not change at all in the rear of the vehicle.

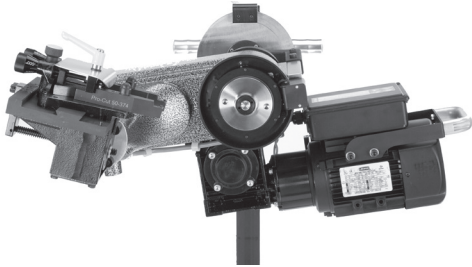

FIG:1 | Lathe in upright position. Note that adjustments to cutting head are simpler in this position. **(NOTE* SPINDLE GUARD 50-1740 NOT SHOWN FOR CLARITY.)**

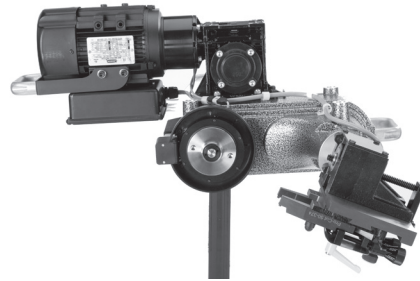

FIG:2 | Lathe in upside-down position. You will need to flip the lathe over into this position to machine one side of the vehicle if there is a dust shield, or other interference behind the rotor. **(NOTE* SPINDLE GUARD 50-1740 NOT SHOWN FOR CLARITY.)**

LATHE PREPARATION CHECK CUTTING TIPS

Before mounting the lathe, check the cutting tips and make sure they are ready for use. The cutting tips are one of the most critical components of the machine. It is vital that they are Pro-Cut brand tips in good condition and properly mounted. Each cutting tip has three corners which may be used. The correctly installed tip is wider on the top and has a groove, or dots, facing up. A tip mounted upside down will produce a surface finish that looks like a record.

You should get at least 7 cuts per corner. However, tip life is affected by variables such as rust or ridges. In order to determine when to rotate tips, monitor rotor finish. If the rotor finish begins to look inconsistent, or feels rough to the touch, tips should be rotated. Tips that are chipped or cracked should never be used.

Be sure that the tip pocket is clean before positioning the tip. Any foreign material pinched under the tip will cause problems.

NOTE 1: The lathe has a powerful 1 hp motor which requires 20 amp service. All extension cords must be at least 12 gage and less than 25 feet; drop light cords are not recommended.

NOTE 2: Use only Pro-Cut Cutting Tips (50-742). Although other tips may fit the machine, only Pro-Cut tips have been specifically engineered in tandem with the Pro-Cut lathe. Using a non-Pro-Cut tip may compromise lathe performance and result in poor surface finish.

This is the premium Pro-Cut tip (50-742). When the tip is mounted correctly, the chip breaker and dots face up.

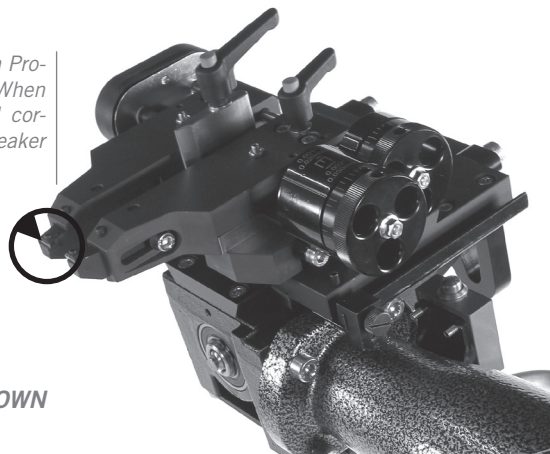

MACHINING ROTORS

In just 4 steps in about 7-9 minutes, any tech can perform top-quality brake work.

Step 1: Mount the Adapter (2 mins.)

Step 2: Set up the Lathe (1-2 mins.)

Step 3: Adjust for Lateral Run-out (1 mins.)

Step 4: Make the Cut (3-4 mins.)

If the four steps are followed properly on each brake job, the Pro-Cut X9 RMS will operate accurately and efficiently.

STEP 1: MOUNT THE ADAPTER (2 Minutes)

The First step is to choose the proper adapter. Most passenger cars require either the four (50-687) or five lug (50-688) Direct Fit® adapter. Some larger passenger cars and smaller trucks use the (50-695) adapter. For most trucks and vans, use the larger adapter (50-691) or the Asian / European variant, the 50-681. This fits 5, 6, 7, and 8-lug vehicles. See the adapter guide on pages 72-73 of this manual, or use the adapter search on the Pro-Cut website for more specific information.

Once you've selected the correct size adapter, try each bolt pattern until you find the one that fits the vehicle evenly. When possible, use the nuts provided with the machine. Hand tighten nuts with an open box end wrench or a torque wrench in a star pattern. Do not use impact wrenches to mount adapters. Nuts should be hand-tightened to 25-30 ft. lbs. Excess torque may damage the adapter.

Some vehicles require the use of a spacer (30-791 or 50-246) which are provided in the lathe package. If the adapter doesn't fit flush and square, use the spacer. Sometimes the holes in the spacer are not needed as the entire bolt pattern will fit in the center of the spacer.

WARNING

The adapters are made of case iron, not aluminum or steel like wheels. They are not designed to withstand the use of impact tools. **DO NOT USE IMPACT GUNS TO ATTACH THESE ADAPTERS!** Twenty to thirty ft.-lbs. applied by hand is plenty to secure the adapter to the vehicle. Excess torque applied with an impact wrench will damage the adapters. ***Warranty does not cover this misuse.***

MACHINING ROTORS CONTINUED

STEP 2: SET UP THE LATHE (2 Minutes)



Step 2: Technician mounts the lathe to the adapter

A. Mount the Lathe to the Adapter

Move the cutting head out so that the tips will not strike the rotor as you mount the lathe.

Next, roll the machine into place and match it up with the adapter. Note that the trolley moves up and down to accommodate different heights. The small dowel pin on the face of the adapter will fit into either of several holes on the run-out adjustment flange. Turn the draw bar knob to thread into the adapter securely connecting the lathe to the vehicle.

NOTE: It is very important that the machine be mounted smoothly on the adapter without prying or forcing. Take the time to align the machine properly in order to avoid damage to the run-out adjustment flange. The large draw bar knob will spin on very easily when the machine is properly aligned, much like installing an oil filter. Tighten it by hand only.

SECURING THE CUTTING HEAD

Vibration is the root cause of most surface finish problems. Be sure the cutting head is securely locked in place. Tight connections here reduce the chance of vibration.

B. Position the Lathe for Cutting

Loosen the trolley handle so that the machine is free to rotate. Rotate the machine so that the cutting head is in a position where there is clearance to make the cut. Be sure to check the back side of the rotor for obstacles. Make sure there will be clearance for the chip deflector as well. **Lock the trolley lever securely so the machine will not rotate when the motor is started.**

STEP 2: SET UP THE LATHE (2 Minutes) (CONTINUED)

C. Position Cutting Head and Set Shut-off Cam

The new Speed-Lock Cutting Head has two lock levers, one closer to the brake rotor (Forward) to release the tool arms, and one farther from the brake rotor (rear) that allows you to lock the cutting head in position once centered over the rotor. The cutting head can slide laterally but is limited by two roll pins; one on either side of the leading edge of the **50-496** plate.

Loosen the forward lever and the rear knob. Slide the cutting head laterally and adjust the tool arm depth knobs (at the rear of the cutting head) so the tool arms are evenly spaced and will clear the rotor. Once centered over the rotor, tighten the rear lock knob to secure the cutting head. If the cutting-head lock knob is not secure, a poor surface finish will result; over-tightening is not required.

NOTE: *The Pro-Cut will mount cutting head up on one side and cutting head down on the other. Always start right-side up; this way, when you proceed to the other side of the vehicle, the offset of the cutting head, and the shut-off cam will already be set.*

Next you will set the shut-off cam. Crank the feed knob in until the tips clear the outside edge of the rotor. Loosen the cam screw and slide the cam back until it contacts the automatic shut-off switch plunger. Tighten the cam screw. The cam will press the shut-off switch when the tips clear the rotor.

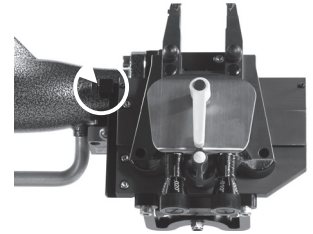

Set the shut-off cam (circled) by loosening the thumbscrew and positioning on the rail so that the cam will depress the stop button when the cutting tips clear the rotor.

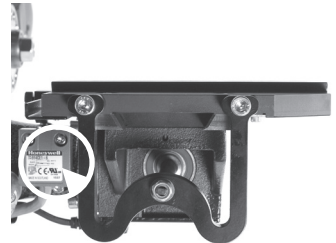

Note the Automatic Shut-Off Switch Above. The shut-off cam will depress the stop button when the cutting tips clear the rotor.

MACHINING ROTORS

STEP 3: ADJUST FOR LATERAL Run-out (1 Minute)

You must adjust for lateral run-out to eliminate wobble (run-out) from the machine before cutting. This procedure ensures the resulting machined rotor will have minimal run-out after cutting. The X9 Rotor Matching System has been calibrated to reduce run-out to less than 0.001" [25.4 micron] or less as measured on the rotor face.

COMPENSATE FOR Run-out

The X9 Rotor Matching System compensates for run-out automatically. With the machine mounted securely to the adapter and all potential interfering items clear of the rotating assemblies, press the motor on switch. With the machine running smoothly, wait approximately 8 seconds, then press and hold the start button on the DRO computer board for 2 seconds. The lateral movement of the lathe as measured at a 12" / 305mm diameter (6" / 152mm from the center of hub) will be displayed on the Digital Read Out (DRO) screen. A clicking sound will be heard throughout the adjustment process, which is the adjustment solenoid changing the angle (at the adjustment flange face) until run-out is reduced to within vehicle specification or less.

This procedure will usually take between 10 to 90 seconds. Total adjustment time depends on a number of factors including initial run-out and the resistance in the hub. Average adjustment time is less than 30 seconds, but may take up to 120 seconds depending on vehicle set-up. When the machine is done adjusting, green lights and a displayed lateral run-out value on the digital display will give feedback on the compensated status of the lathe.

When the machine is done adjusting, a displayed value on the DRO will give feedback on the status of the lathe. To make the DRO easier to read at a glance, we removed leading zeros and set the output to show whole thousandths to the left of the decimal point and tenths of a thousandth to the right of the decimal point. For example, a measurement of 0.0015" [38 micron] will be displayed on the DRO as 1.5 [38 micron], or one and a half thousandths or thirty eight microns. Green lights for "READY TO CUT" and "OPTIMUM" will also be illuminated as a backup to the DRO.



Detail of the computer box.

STEP 3: ADJUST FOR LATERAL Run-out (1 Minute) CONTINUED

If the TRY AGAIN light is illuminated, the machine is unable to fully adjust for run-out. This difficulty could be due to looseness of fittings, irregular run-out, damage to wheel bearings or other components, or other factors relating to set-up. The best procedure is to loosen the machine from the adapter, check adapter and vehicle setup, rotate the adapter locator pin 180 degrees, and attach the machine again. Make sure that the machine is adequately supported by the trolley. Run the adjustment procedure and the machine will again adjust for run-out. If TRY AGAIN appears repeatedly, there is most often a problem with the vehicle. You should dismount the machine and check for a damaged wheel bearing or CV joint. Such problems will have to be addressed before match-machining is possible.

If the machine seems to be having excessive difficulty in adjusting for lateral run-out, consult the troubleshooting section on Page 33.

NOTE



DRO computer in READY mode.



DRO computer compensated for lateral run-out to 0.0006" and ready to cut.

MACHINING ROTORS

Step 4: MAKE THE CUT (4 Minutes)



STEP 4. Technician sets cut depth. *SPINDLE GUARD 50-1740 NOT SHOWN!

1. With the motor still running, loosen the forward lock lever on the cutting head to allow cutting depth adjustment.
2. Turn cut-depth knobs counter-clockwise until the tips can clear both sides of the rotor. Crank the cutting head in to the middle of the braking surface of the rotor.
3. Start with the inside (behind the rotor) tool arm. Turn the depth knob clockwise (tighten) until the tool tip just barely makes contact (scratches) with the rotor surface. You can listen for the contact. Next move the outside tool arm in until it also makes contact.
4. Now advance the cutting head in towards the center of the rotor making a "running light scratch". If there is a large ridge on the outer edge of the rotor, you may remove that as well by manually feeding the cutting head slowly over that ridge. Be careful not to crank the cutting arms into the "hat" of the rotor. **Damage caused by advancing the cutting arm into the hat of the rotor is not covered by warranty.**
5. When you are at the inside edge of the pad contact surface, you may adjust for depth by turning the depth knobs clockwise. Each line of the knob represents cutting tip movement of 0.0025" / 0.064mm. Cut at least 0.005" / 0.13mm (or two lines) on each side with each pass. The maximum depth is 0.020" / 0.51mm per side, per pass. The exceptions to this rule would be extremely large and thick rotors such as on a Medium Duty truck like the Ford F550 or larger, or very thin solid rotors such as on the rear of a Cadillac DeVille. In these applications, the depth rule is reversed and the minimum cut can be reduced to 0.0025" / 0.13mm per side per pass, and the maximum cut depth should be limited to 0.005" per side per pass. Other specialty rotors, such as cross-drilled or slotted, may also require a reduced cut depth. **Note: see our web site for tech-tips on cutting larger and specialty rotors.**

WARNING

It is extremely important not to touch the hat of the rotor with the outer tool holder. This will damage or break the tool holder plate. This type of damage is **NOT COVERED BY THE WARRANTY.**

MACHINING ROTORS

Step 4: MAKE THE CUT (4 Minutes) *CONTINUED*

- Now that you have adjusted for depth, tighten the forward lock lever (over the tool arms). This lever must be tight to minimize vibration. **For safety, it is advised at this time that you turn the motor off. Place the chip deflector/silencer around the rotor and over the cutting tips.** Grooves in the chip deflector/silencer will fit snugly over the cutting tip screw heads when installed correctly. This silencer is very important, and it should be used on every rotor. There are currently two types of chip deflector/silencers. The first, the 50-703 standard version, is used in most applications. The second, the 50-754, has double thick silencer blocks and a lock clip to increase pressure on the rotor. The 50-754 chip deflector/silencer works well on the thin solid rear rotors. In 2012 Pro-Cut will introduce a third type, which has wide pads and a wider wire loop which will make this type function better on thicker rotors.
- Once cut depth is set, tool arms are locked down, and silencer is secure, you may turn the motor back on. Press the feed engagement knob to engage the automatic feed. Provided that you previously set the shut-off cam correctly, the lathe will shut off when the cut is complete. The cut will take two to four minutes depending on the size of the rotor.

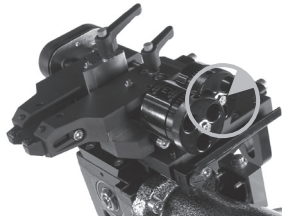

Turn the dials clockwise to advance the cutting tip depth. Each line on the dial indicates 0.0025"

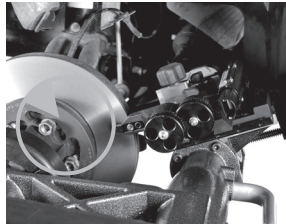

The chip deflector rides over the cutting arms as shown above. The chip deflector should be used every time.

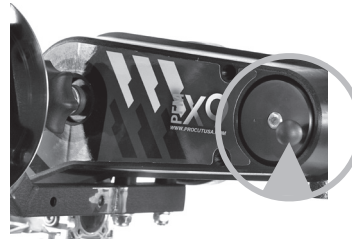

Move the cutting head by turning the knob shown above, clockwise for away from the rotor, counter-clockwise for towards the rotor.



Pictured above is the 50-754, which has double thick silencer heads and a lock clip to increase pressure on the rotor.

MACHINING ROTORS

Step 4: MAKE THE CUT (4 Minutes) *CONTINUED*

8. When you are finished cutting, loosen the cutting arm lock lever, and turn the dials counter clockwise so they will clear the larger thickness of the second rotor. Loosen the draw bar knob and remove the lathe from the adapter. Be careful not to bump either the rotor or the wheel with the cutting head as you dismount the lathe. Take special care not to bump the tips into the rotor.

9. Before removing the adapter from the first side, measure and record the lateral run-out on the rotor. Also measure and record the thickness to ensure that it is above “machine to” specification. You may compare to factory specifications in the Pro-Cut Brake Spec Guide provided, or other reliable certified source. When you have finished your measurements, be sure to clear the hub, caliper bracket, and speed sensors of any brake chips, dust or debris. ***Optional but recommended:*** With the motor running, finish sanding with a 150 grit sandpaper on a sanding block on each side of the rotor for 1 minute will serve to improve the surface roughness average (Ra) by up to 25%. Excellent surface finishes provide the least amount of initial brake noise and the best customer satisfaction.

10. Cleaning the rotor surface after machining to remove all dust and debris is very important in the overall quality of the brake job. Pro-Cut recommends using liberal amounts of warm water with a mild detergent and drying thoroughly with clean towels to be certain all loose material is removed.

MACHINING THE OPPOSITE SIDE

1. Loosen the trolley disc lock lever and rotate the machine into the upside-down position.
2. The procedure for cutting in the upside-down position is the same, though fewer steps are needed as the lateral position of the cutting head relative to the rotor is already set. The lathe mounts in the same manner. Often, the shut-off switch will still be depressed from the previous cut, so the machine will not turn on until you advance the cutting head slightly. The cutting arms will also still be advanced in from the last cut, so be sure to loosen the forward lock lever and spread the tool arms before feeding the head towards the center of the rotor. Measuring and adjusting for run-out is exactly the same as in the upright position. The entire cutting process is also the same, right down to the chip deflector/silencer which mounts in the exact same position.

NOTE

Be sure the auto shut-off is not still engaged from your first cut!

WARNING

Advancing the cutting head towards the hat of the rotor requires even more care when upside down. Be careful not to bump the hat of the rotor!

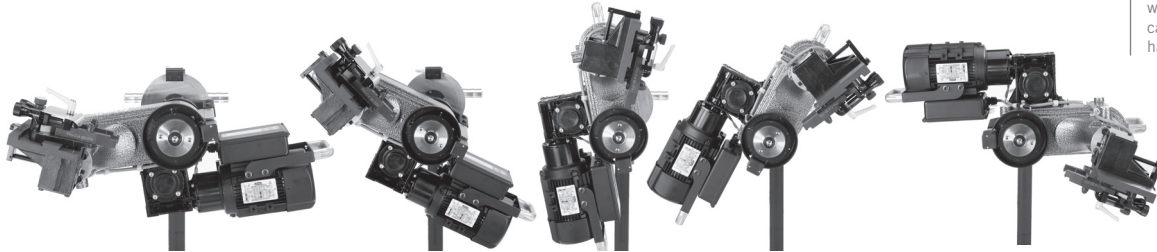

After loosening the trolley handle, the lathe can be flipped over to machine the opposite side of the vehicle.

(NOTE SPINDLE GUARD 50-1740 NOT SHOWN FOR CLARITY.)*

MACHINING ROTORS

VEHICLE REASSEMBLY

Be sure to torque all lug nuts to manufacturer's specification with a torque wrench or other calibrated tool. Excess or uneven torque can deflect the rotor and actually induce additional run-out, destroying the accuracy of the rotor matching process.

When machining (and any optional sanding) is complete on both sides, all debris must be removed and rotor surfaces completely cleaned with soap and water. Cast iron dust left on the rotor can cause brake noise. All surfaces should be cleaned of chips and dust. Special care should be used in making sure that ABS sensors are free of debris. Reassemble the brakes and wheels to the manufacturer's specifications.

HELPFUL HINTS FOR CUTTING ROTORS USING A PRO-CUT LATHE

- Inspect cutting tip edge for wear and damage.
- Be Sure that the gib is properly adjusted on the slide plate.
- Be sure that the vehicle is in neutral.
- Remove the wheel and caliper on both sides of the vehicle and stabilize the opposing rotor so it does not rock.
- Be sure that the Emergency Brake is released.
- If ambient temperature is well below freezing and the vehicle is all-wheel drive, warm vehicle up by driving for 5 minutes.
- If cutting a vehicle with limited slip, disconnect the drive shaft if resistance is too great.
- If there is an electronic traction control control switch, turn it to 'off'.

HELPFUL HINTS FOR CUTTING ROTORS USING A PRO-CUT LATHE

- If the vehicle has a floating locking rear axle, remove the axle prior to attaching lathe.
- If AWD vehicle and all 4 wheels turn, remove all 4 wheels and calipers.
- After cutting rotors, sand each side for 1 minute with 150 grit sandpaper, then wash with soap and water until all residue is removed.

MAINTENANCE

The Pro-Cut lathe is simple and rugged. With just a few maintenance tips you can ensure a long and profitable life for your machine.

Check cutting tip edges. If there are chips or dings, turn or replace the tip. Be sure they are right-side up so that the groove and dots are visible. Each tip has three cutting points. When worn out, replace them using a 2mm allen wrench as the one provided with the tool kit. Although the tips must be securely tightened, do not over-tighten them either. When changing tool tips, clean the threads and put a spot of Vaseline® (or thick grease) in the bottom of the screw hole before tightening the tool bit screw. The Vaseline / grease will stop chips from accumulating in the hole and rusting in place. If chips do rust in place, they can often be dislodged by poking a needle through the hole.

Clean the slide plate **(50-496)** and tool holder plate **(50-293)**, taking special care that there are not chips or dirt wedged in the dovetails or under the tool arms. Clean loose cast-iron chips from the magnetic tip on the adjustment flange to maintain a clear signal to the computer. Check the electrical connections and cord for cuts in the insulation or for wear.

WEEKLY MAINTENANCE

Lubricate the cut depth adjustment wedge threads with a thin coat of light machine oil.

Check the slide plate (**50-496**) for lateral play. Lateral play often causes ridges and machining grooves when a rotor is re-surfaced. To check for lateral play, grab the slide plate assembly and try to wiggle it side to side. If there is motion, you will need to tighten the Gib (See “Tightening the Gib” on Page 32).

TROUBLESHOOTING ASSURING A SMOOTH FINISH

NOTE

The Pro-Cut X9 should provide a smooth surface finish on every cut, free of chatter, tone, or roughness. If your machine leaves a substandard, “chatter” or rough finish, you need to find the problem. The following pages are the common sources of poor surface finish and ways to remedy the problem.

Brake performance is dependent upon rotor surface finish as well as minimizing lateral run-out. The Pro-Cut lathe is designed to give you a superior surface finish on any rotor as long as proper maintenance is followed.

Minimizing vibration during machining is the key to high-quality surface finish. It is critical that all contact points between the rotor and the lathe are secure – specifically, the connections between lathe and adapter; the slide plate and the lathe; the cutting head and the plate; and the tips and the tool holders. Looseness in any of these areas will compromise lathe performance and surface finish.

CHECK CUTTING TIPS

The cutting tips must be right-side up. Dots face up. The cutting tips should not have chips or dings in the surface of the points. Do not take cuts of less than 5 thousandths of an inch / 0.13mm unless necessary for non-vented, drilled, or rear of dual wheel trucks. Cuts of 5 to 10 thousandths / 0.13-0.25mm will provide the best surface finish and the longest tip life for vented rotors of normal size.

MAKE SURE THE CUTTING HEAD IS SNUG

On each brake job, the technician must center the cutting head. Once the head is centered, it is vital that the technician tighten the cutting head lateral lock knob securely. Failure to do this may result in chatter.

USE THE CHIP DEFLECTOR

The chip deflector included with the lathe is a critical component. The pressure of its pads provides a great deal of dampening that reduces the chance of vibration while cutting. The chip deflector must be used on every cut to ensure proper finish. New chip deflectors can be purchased directly from Pro-Cut. For thin, solid rotors a heavy-duty chip deflector/silencer (**50-754**) is available.

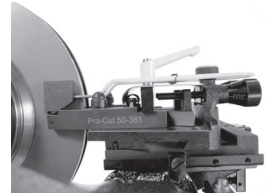

The chip deflector reduces vibration and must be used on **EVERY** cut.

CHECK FOR BENT TOOL HOLDER PLATE

Check the tool holder plate for damage. Slide a 0.003" / 0.08mm feeler gage between the tool holder plate (50-293) and the tool arms. If it can be inserted freely your tool holder plate is damaged. A damaged tool holder plate will often cause a vibration during the cut. This will leave a poor surface finish on the rotor.

TIGHTENING THE GIB

Poor finish quality can be the result of a loose slide plate. As wear occurs between the slide plate and the gear box it rides on, you must take up the slack. You do this by tightening the moveable wedge we call the “gib” (50-463). **If the cutting head can be moved from side to side at all, it should be tightened.**

TO ADJUST THE GIB (50-463):

1. First loosen all five set screws (with 2mm allen wrench) by freeing the 8mm lock nuts and loosening the allen set screws, and remove the 2 feed block screws with a 6 mm allen wrench.
2. Remove the **50-496** plate and gib completely, and clean the contact surfaces. Locate the plate in the middle of the rail with the gib between the plate and the rail. Be sure the 5 notches of the gib are aligned to catch the allen set screws as they're tightened through the plate.
3. Tighten each allen set screw until you feel it snug against the gib.
4. Hold light pressure with the allen wrench as you lock the screw down with the 8mm lock nut.
5. After tightening each nut, slide the plate to make sure there is no binding. When the gib is adjusted properly, the plate will have some resistance as it slides, with no lateral movement possible.



| Detail of the gib adjustment screws

To reattach the feed block, move the slide plate as far forward as it can travel, wind the feed block in to meet the plate, and then install and tighten the two 6mm allen cap screws. This ensures that the feed block will be properly centered. Wind the head back out and the machine is ready for use.

LATERAL Run-out ADJUSTMENT *The X9 can be calibrated to adjust to tighter or looser standards.*

If the machine is having difficulty adjusting for lateral run-out, first assess the vehicle being serviced. If lateral movement is rough or uneven due to damaged vehicle components, these components must be repaired or replaced before rotors are match-machined. It is also important that the machine be supported by the trolley during adjustment.

CALIBRATION PROCEDURE

The Pro-Cut X9 Rotor Matching System is calibrated with an acceptance number from the factory. Normally, this will never need to be changed. **Please call Pro-Cut Service Department before attempting calibration procedure to confirm that this is the problem.** To *tighten the calibration* you need to *lower the acceptance number*. To *loosen the calibration*, you need to *raise the acceptance number*.

Please see pages 34 - 35 to raise or lower the acceptance number.

TROUBLE SHOOTING HOW TO RAISE OR LOWER THE ACCEPTANCE NUMBER

1. With the brake lathe plugged in **but not turning**, push RESET and release, and wait for the READY TO START light to be illuminated
2. With the READY light illuminated, press and hold the CALIBRATION button (located just below the lights) until the ADJUSTING light illuminates, then release the CALIBRATION button.
3. Now the machine is displaying the acceptance number. Generally this should be 1.0.
4. To raise the acceptance number (loosen the calibration), press the START button once. To lower the acceptance number (tighten the calibration), press the CALIBRATION button once. The acceptance number will change in increments of two. After raising or lowering, hit the RESET button to save the change.
5. Once you have raised or lowered the acceptance number by two and hit RESET, test the machine to ensure that the problem has been solved. You may need to repeat the procedure once or twice to fully solve the problem.

If you have any difficulty or questions about executing this procedure, call Pro-Cut.

TROUBLESHOOTING

All X9 DRO machines are typically calibrated to a value of 1.0 from the factory. This value should give the best performance and should only be changed at the direction of a qualified Pro-Cut service tech.



NOTE

Higher binary codes will yield a wider acceptance range. Lower binary codes result in tighter acceptance bands.

START BUTTON

RESET BUTTON
CALIBRATION BUTTON

DRO COMPENSATION INSTRUCTIONS

Your new X9 On-Vehicle Lathe is equipped with our latest innovation, the all new DRO. DRO, which stands for "Digital Run Out," combines several new features to offer you increased accuracy as well as lathe diagnostics and efficiency tracking. By checking these values on a monthly basis, managers can track their ROI based on the machine usage. Pro-Cut Service Technicians can also check the accuracy of the machine over time.

The first screen that you will see when the machine is plugged in (after the computer "boots up") is the Ready Mode.

Once you initiate the run-out compensation process by pressing the START button, the "live" lateral run-out will be displayed. In this mode, the lathe will display actual run-out, or how much the lathe is moving laterally, as recorded in thousandths and tenths of a thousandths of an inch. To make the display easier to read at a glance, we've removed the leading zeros from the display and simply have one digit to the left of the decimal, or the whole thousandths, and one digit to the right of the decimal, or the tenths of a thousandth. Once the compensation cycle is complete, the final run-out will be displayed on the screen for four minutes, or about the duration of one cut cycle. After four minutes the screen will revert back to the READY screen.

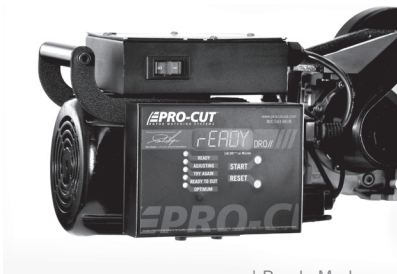

| Ready Mode.



| This display of final compensation equals .0006"

DRO EFFICIENCY TRACKING

The remaining screens are accessed through the START button and are scrolled through by continued pressing of the START button. The machine first must be in the Ready mode and the **motor must be off**. Press and hold the START button until all of the lights come on, then release and the Hour screen will be displayed. Then, press the START button again and the number of hours that the motor has run will be displayed in hours and tenths of an hour.



| The first diagnostic screen



| This value represents hours and tenths of an hour that the motor has to run.

DRO EFFICIENCY TRACKING

Press the START button again and the word "Total" will be displayed. Press the START button once more and the total number of times the machine has compensated will be displayed.



This value represents the total number of completed compensation cycles. Estimating one cycle per cut, we can begin to establish ROI.

DRO DIAGNOSTICS

Press the START button once more and the "A.Adj." will be displayed. Press the START button once again and the average adjustment (compensation) time over the course of the total number of compensations the machine has completed will be displayed in seconds.



This value represents the average compensation time recorded in seconds over the life of the lathe.

DRO DIAGNOSTICS CONTINUED

Press the START button again and the word "5 Adj." screen will be displayed. Press the START button once more and the last five adjustment cycle times will be displayed in seconds.

Press the START button once more and you will reach the units display toggle. Pressing 'Start' will toggle between inch and metric (mm for thickness and microns for runout) display modes.

Press the START button one more time to enter Thickness Calibration mode. This is for G2X equipped lathes. Further information is found on page 50.



Display of average compensation time of the last 5 successful compensation cycles.

X9

G2X TECHNICAL SUPPLEMENT



YOUR LATHE PACKAGE

The G2X upgrade package allows for live display of rotor thickness on the DRO screen. The 50-1200 Lateral cutting head replaces the 50-220 cutting head. This new cutting head allows us to use a single sensor to measure the distance between the arms, and thus the distance between the carbide insert tips.

- 50-1200** Lateral Cutting Head
- 50-1206** Slide Sensor Assembly
- 50-1148** Gage Pickup Module

G2X Overview

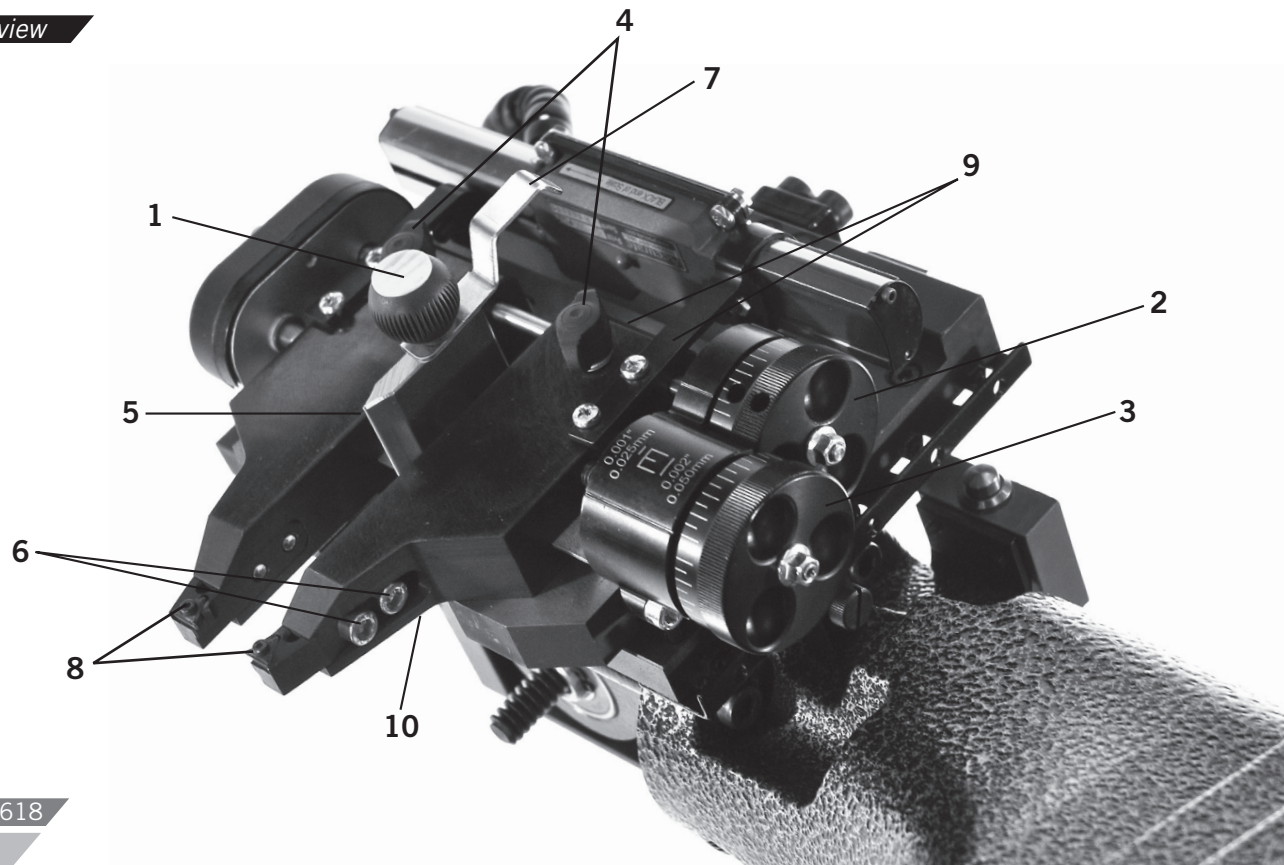

G2X COMPONENTS 50-1200 Cutting Head

1. Position lock knob
2. Adjustment dial - inboard
3. Adjustment dial - outboard
4. Tool arm position lock knobs
5. Rotor centering pointer
6. Throat depth lock screws
7. Silencer/deflector retainer
8. Carbide cutting inserts
9. Tool arm gib adjustment screws (*Obscured*)
10. Travel limit screw (*Obscured*)

THE 50-1200 CUTTING HEAD

Unlike Pro-Cut's earlier designs, this cutting head's arms move from side to side. The adjustment knobs face the user. The depth adjustment dials are offset as a reminder - the one nearest you (**AA**) adjusts the outboard (away from vehicle) depth of cut and the one farther from you (**BB**) adjusts the inboard (nearest to vehicle) depth of cut.

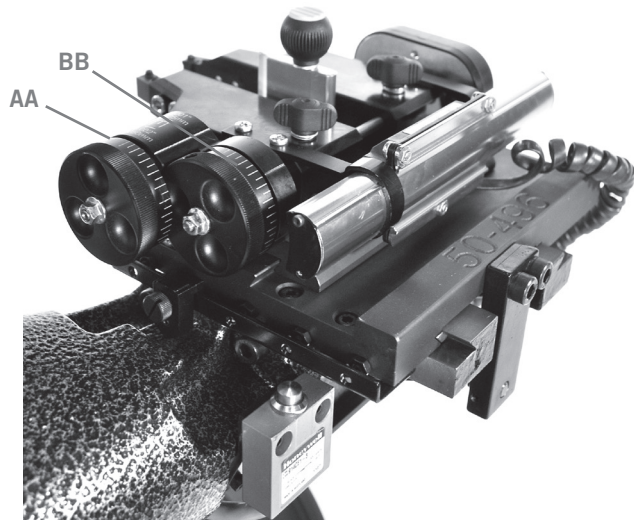

Detail of outboard adjustment knob (AA) and inboard adjustment knob (BB)

The dial knobs have small and large lines. Each small line is 0.001"[0.025mm] depth and each large line is 0.002"[0.050mm] depth. Each full turn of these knobs moves the arm almost 0.050"[1.25mm] - nearly twice what the older style cutting heads removed per turn, so please take care not to cut too deeply by accident.

Detail of small adjustment lines 0.001" / 0.025mm depth and each large line of 0.002" / 0.050mm depth.

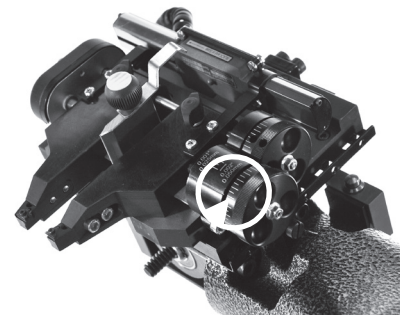

50-1200 CUTTING HEAD

TO USE THIS CUTTING HEAD:

1. Loosen the position lock knob.
2. Using the rotor centering pointer as a guide, center the cutting head about the rotor. Tighten position lock knob.
3. Adjust each arm's depth of cut as desired and then lock each arm with its' lock knob. It is not necessary to use much force on the tool arm lock knobs. Finger snug is plenty.

Turn off the lathe to stop the rotor from spinning and then fit the silencer/deflector about the rotor, and secure the back end of it under the retainer. This will help prevent it falling away prematurely.

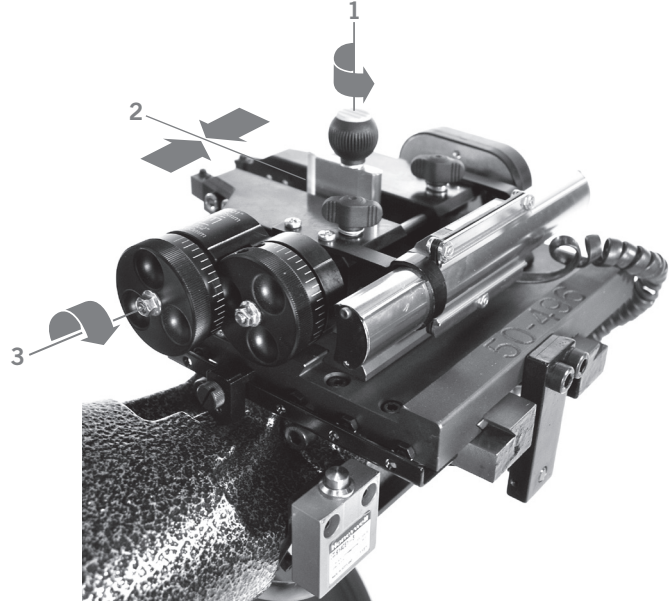

NOTE: Use only Pro-Cut Cutting Tips (50-742). Although other tips will fit the machine, only Pro-Cut tips have been specifically engineered in tandem with the Pro-Cut lathe. Using a non-Pro-Cut tip may compromise lathe performance and result in poor surface finish.

USING THE 50-1200 CUTTING HEAD CONTINUED

If a rotor has an extra wide face width, or if the inboard face is wider than the outboard face, the inserts may be adjusted to allow for staggered cheeks by loosening the throat depth lock screws, moving the insert holder to the desired position and then re-tightening the throat depth lock screws.

50-1200 CUTTING HEAD ASSEMBLY

TO FIT THE TOOL HOLDER PLATE TO THE SLIDE PLATE:

1. Loosen the travel limit screw until it no longer crosses the slot on the bottom surface of the tool holder plate.
2. Carefully loosen the position lock knob until the cam on the bottom surface is just below flush with the bottom surface of the tool holder plate.
3. Slide the tool holder over the male dovetail on the slide plate.
4. Once in place re-tighten the position lock knob (4) and the travel limit screw (1).

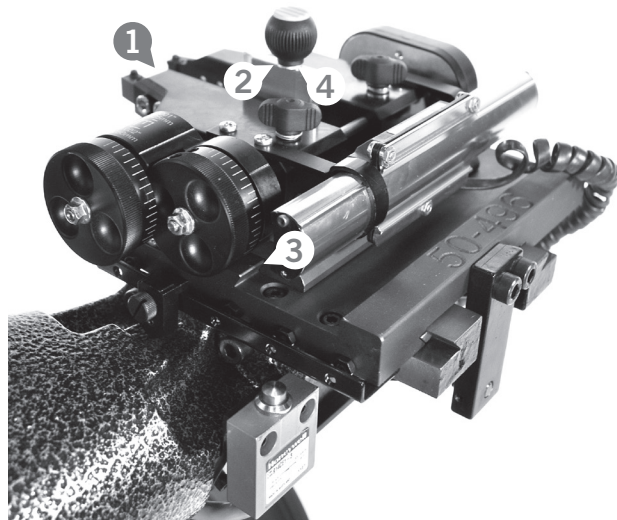

THE SLIDE SENSOR 50-1206

THE SLIDE SENSOR is an absolute encoder device, nearly identical to those used in digital calipers. When mounted to a correctly adjusted cutting head and properly calibrated it should give an accuracy of ± 0.005 " [0.127mm]. The sensor itself is enclosed in a case to prevent dust contamination. This is a precise instrument, please take care. Its housing will prevent most damage, but it is not intended to take large loads or impacts nor be used as a handle.

50-1206 COMPONENTS

1. Inboard mounting bracket
2. Outboard mounting bracket
3. Slide pin
4. Slide pin clamp screw
5. Data cable

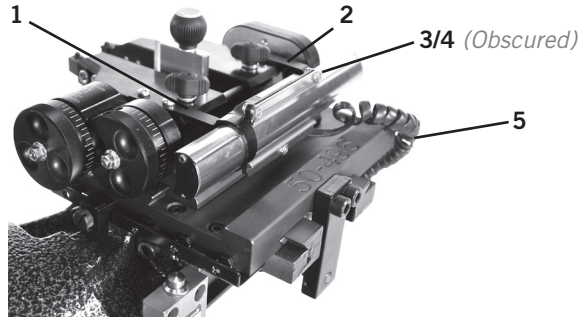

THE SLIDE SENSOR 50-1206 ASSEMBLY

Loosen, but do not remove, the slide pin clamp screw. Using the four screws provided mount the inboard and outboard mounting brackets to the holes tapped in the top surface of the tool arms. You will likely need to adjust the slide side to side, or move the arms to match the separation of the brackets. Before tightening the bracket screws, please make sure the slide sensor is parallel to the rail on which the arms move. Once you're sure this is parallel, tighten the four mounting bracket screws and the slide pin clamp screw.

THE GAGE PICK UP MODULE 50-1148

The Gage Pickup module has two jobs. It decodes the data from the slide sensor (aka the gage) and sends it to the main lathe computer for display. When used in a full Gyr package, it also detects when a cut is being made (the pickup).

FEATURES:

1. Mouning holes
2. 8 pin connector
3. 6 pin connector

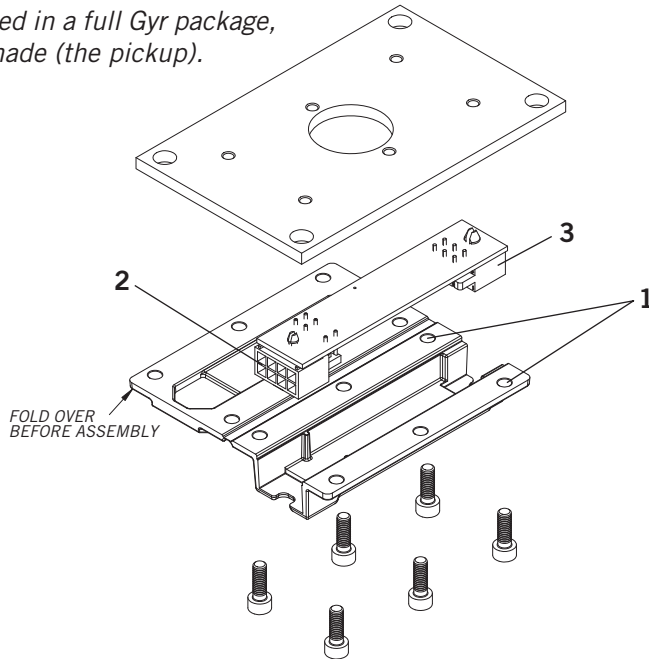

Remove the cover on the bottom of the bevel gearbox assembly. Replace it with the 50-1148 assembly, taking care to aim the eight pin connector towards the lathe body. With the lathe unplugged from AC power, seat the 6 pin connector from the slide sensor, and the 8 pin connector from the lathe's harness. These are waterproof connectors and they seat firmly. Please make sure the small catch latches over the post on the top of each connector to ensure a complete connection. Re-power the lathe.

**NOTE: The Gage Pickup module also performs cutting detection, but this feature is not used unless you upgrade to a full Gyr package.*

ELECTRONIC READOUT:

When the lathe is plugged in you will see three letter/number combinations if you have connected everything properly:

LA### Lathe Adjustment Module & Version Number *(You will see digits, not the # symbol)*

DC### Display Control Module & Version Number

GP### Gage Pickup Module & Version Number

If the Gage Pickup Module is not connected you will see E.GPM instead of GP###. Always unplug the lathe when connecting or disconnecting lathe electronics. It is unlikely that doing so while the lathe is powered will cause any harm, but the electronics work best when they are all powered on and off simultaneously.

G2X CALIBRATION

Before the lathe may be used to cut rotors, the slide scale and cutting head assembly must be calibrated. This calibration procedure should be performed at least monthly, or any time the slide scale is removed from the cutting head. It is not necessary to re-calibrate every time an insert is rotated, the inserts are very precise and do not vary much. You should, however take care that the insert has not shifted or rotated in its' pocket after tightening the tip screw.

CALIBRATION STEP 1:

Set the calibration block with 0.800" / 20.32mm side between the tool arm carbides. It should be as square as possible and just barely touching each carbide. If you have it set correctly, you will not be able to rotate it except along the line formed by the two carbide inserts touching it. Be careful not to over-tighten the carbides - they are harder than the calibration block and will damage it if carelessly tightened, also over tightening may chip the carbide itself. When properly seated the calibration block will 'hang' between the carbides. Please note that the gage block has one pair of sides which is NOT 0.800". If you are unsure, check with a digital caliper to make sure you use the correct faces when calibrating.

CALIBRATION STEP 2:

To calibrate the thickness you must enter the same menu as you use to read the DRO Efficiency numbers (see page 37). With the motor off, press and hold the Start button on until all of the lights come on and then release it. Press the Start button multiple times until you see a screen that says 'H0.800' or 'H20.32' if in mm mode.

CALIBRATION STEP 3:

With the display in 'H' mode, and the 0.800" / 20.32mm thick calibration block in place, press the CALIBRATION button, the same one used to set the LRO Acceptance number. You will hear a beep. When you have done this, you can press the Reset button to exit the H mode or use the Start button again if you wish to read the DRO numbers out or switch between inch and mm display mode.

CALIBRATION STEP 4:

The cutting head and slide sensor are now calibrated to read thickness correctly. To check calibration you can put the gage block between the inserts again and re-tighten. If you read between 0.796" / 20.22mm and 0.804" / 20.42mm you are properly calibrated.

USING THE G2X

If you rotate the adjustment knobs, you will see the DRO display transition to thickness display. After 8 seconds of inactivity the display will alternate between the thickness reading and whatever else had been on screen. Operation of the DRO remains unchanged. You turn on the motor and press the Start button.

G2X SERVICE CONSIDERATIONS

A properly set up and adjusted 50-1200 cutting head will provide smooth yet firm arm motion with minimal knob backlash. If you are having difficulty turning the dials when the arm knobs are backed off, or if the dials turn very easily then adjustments need to be made to the assembly. A poorly adjusted cutting head can cause poor rotor surface finish.

The most common cause of poor dial feel is mis-adjustment of the tool arm gibs. Like the slideway gib adjustment there is a nut and a set screw. The nut must be loosened and the set screw tightened to remove any play between the arm and the arm guide, but it must also not be overly tight. The nuts are all-steel lock nuts, so they turn firmly. Once the set screw is properly adjusted the lock nut must be tightened without disturbing the set screw position. Adjust both arms until you have firm but smooth dial feel. If you have trouble with this procedure please contact Pro-Cut's service department and we will be happy to help.

ISSUE *No Thickness Measurement Data.*

TROUBLESHOOT One of the white rectangular cables connect to the device under the feed mechanism are partially or not fully connected. To solve this:

1. Power off the lathe by unplugging it.
2. Re-seat these cables firmly.
3. Power the lathe on.

X9

GYR TECHNICAL SUPPLEMENT



WHAT IS GYR?

GYR is not a machine itself, but rather a system that is designed to work with your Pro-Cut Rotor Matching lathe to make it the most powerful brake service tool you've ever seen! The GYR system brings together modern hardware like a touch screen tablet and a hand held bar code scanner and integrates them with our proprietary linear transducer, control board, and finally ties it all together with our unique purpose built software program.

GYR measures every rotor live and compares to brake specification data which can be updated annually. The GYR system can provide customer reports and management reports. GYR also provides cutting tip usage tracking, and direct online access to Pro-Cut for assistance at any time.

Before GYR, in order to perform the perfect brake job, you needed a brake specification guide, a dial indicator, a rotor micrometer, and a Pro-Cut Lathe to give a great finish and eliminate lateral run out. Now all of those capabilities are integrated into one, easy to use system, and now brake service will never be the same again!

INTEGRATION WITH YOUR LATHE

Please see earlier sections of this manual for basic lathe usage instructions, diagrams, and see the G2X section for cutting head and slide sensor setup and calibration. This section of the manual only covers the GYR specific components. Once your IT department has followed the IT set up procedures, and your local Pro-Cut Representative has installed all the GYR components, you're ready to do your first brake job!

GYR SPECIFIC COMPONENTS

1. Tablet touch screen PC loaded with GYR proprietary software
2. GYR Application Software
3. Power distribution box
4. 50-1250 Cutting Head

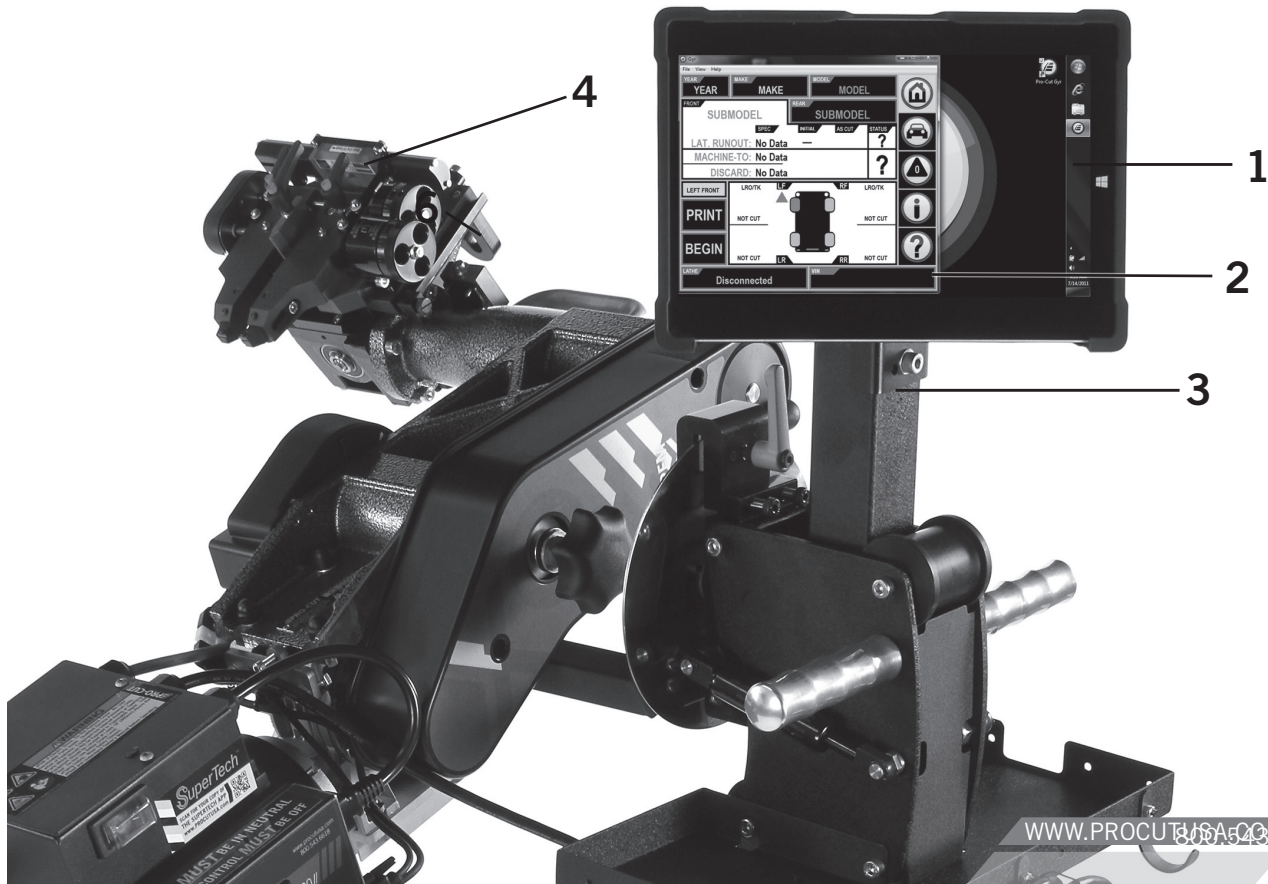

SETTING UP YOUR GYR

The GYR uses a web based data collection site, so you will need to have wireless internet access to best utilize the system's many features. Please follow the following IT set up instructions to prepare for proper installation of your new GYR system.

TECHNICAL IT EQUIPMENT REQUIREMENTS:

- Internet connection with configurable firewall.
- Wi-Fi enabled network of B/G or N with enough range to cover the areas where the GYR Rotor Matching System will be used.
- A printer that the GYR Rotor Matching System will print to that is accessible from the Wi-Fi Network.

GYR Process: 4 Easy Steps

1. *TECH SCANS VEHICLE*
2. *VEHICLE INFO LOADED INTO TABLET*
3. *ROTOR MATCHED IN 7-9 MINUTES*
4. *PERFORMANCE RESULTS AUTOMATICALLY SAVED TO ONLINE DATABASE*

SETTING UP YOUR GYR CONTINUED

GYR TABLET CONFIGURATION:

- GYR Tablet PC needs to be setup on Wi-Fi Network.
- GYR Tablet PC needs to have a printer added and set as default.

NETWORK MODIFICATIONS / FIREWALL CONFIGURATION:

- Open ports for GYR Tablet PC MAC or IP address in firewall:
 - HTTPS: TCP Port 443 (For result reporting)
 - HTTP: TCP Port 80 (For Pro-Cut main support site page access)
- White list all procutusa.com domains. This will allow result viewing, software and database update capabilities.

OPTIONAL

- The GYR Tablet comes with Windows 7 Professional which can be placed on the local domain.
- Pro-Cut offers technical support through “Log Me In - Rescue,” which allows Pro-Cut Service limited access to local computer networks.

FOR TECH SUPPORT, CALL 800.543.6618. PRESS #2 FOR SERVICE.

SERVICE CORRIDOR CONCEPT







Once the GYR components are set up and tested, you're ready to begin the brake service. The steps are simple, sequential, and the program will guide you through the process giving you help along the way. We call this the service corridor.

To Begin:

1. Plug in the power cord, turn on the tablet PC, log in to Windows if necessary and launch the GYR application by selecting the GYR icon.
2. The GYR application will show the most recent vehicle that was serviced, if this is not correct, you will need to enter the new vehicle information with the scanner.

SCREEN 2010 Dodge Charger Police Package is selected in this example»







3. Scan the vehicle's bar code VIN plate or label, normally found in the driver's side door jamb. The red scan line will change to a green dot and the scanner will beep when you have successfully scanned the VIN.
4. Insert repair order, technician name, mileage of the vehicle, and causal code if any using the drop down keypad on the touch screen.
5. Select the appropriate front or rear wheel you are servicing
6. Touch the "Begin" square on the touch screen.

YEAR	2010	MAKE	DODGE	MODEL	CHARGER	    
FRONT	Police Pkg		REAR	Police Pkg		
SPEC	INITIAL	AS CUT	STATUS			
LAT. RUNOUT:	0.025mm	—	0.010mm	✓		
MACHINE-TO:	26.42mm	19.09mm	19.09mm	✗		
DISCARD:	No Data					
RIGHT FRONT	LRO / TK	LF	RF	LRO / TK		
PRINT	0.01 mm			NOT CUT	?	
	18.79 mm					
BEGIN	0.01 mm	LR	RR	NOT CUT		
	18.79 mm					
LATHE	Connected			VIN		

SERVICE CORRIDOR CONCEPT CONTINUED

SCREEN LEFT-REAR Wheel selected with LRO / TK specs displayed on screen»

7. Follow the instructions given on the yellow command bar in the center of the screen.
8. Select the proper adapter and attach to the vehicle's hub; The part number of the correct adapter will be displayed. If you would like visual identification of the adapter, simply touch the part number and an image will be displayed.
9. Connect the lathe to the adapter per the instructions on page 19.

YEAR	2010	MAKE	DODGE	MODEL	CHARGER	
FRONT	Police Pkg		REAR		Police Pkg	
	SPEC	INITIAL	AS CUT	STATUS		
LAT. RUNOUT:	0.025 mm	—		?		
MACHINE-TO:	2.45mm		18.62 mm	✓		
DISCARD:	No Data					
ATTACH ADAPTER						
	ADAPTER:	COLOR	PAT NO.	MORE INFO.		
	50-688 r1	Yellow	1			
NEXT	REQUIRED PARTS:					
	SPECIAL PROCESS:					
LATHE	Connected			VIN		

SERVICE CORRIDOR CONCEPT CONTINUED

10. Turn the lathe motor on and adjust for lateral run-out by touching the green “Begin LRO Adjust” button on the touch screen.

YEAR	2010	MAKE	DODGE	MODEL	CHARGER	
FRONT	Police Pkg		REAR	Police Pkg		
	SPEC	INITIAL	AS CUT	STATUS		
LAT. RUNOUT:	0.025 mm	—	0.018 mm	✓		
MACHINE-TO:	26.42 mm	18.62 mm 20.31 mm		✓		
DISCARD:	No Data					
LRO ADJUSTMENT IN PROCESS						
	LATERAL RUNOUT:		0.025mm			
END LRO ADJ.						
LATHE	Connected			VIN		

NOTE:

LRO Adjustment in Process

11. Once the lateral run-out is corrected “LRO Adjust Complete” will be displayed in the yellow command bar, and the actual LRO will be displayed as well.
12. Touch the “Next” command in the lower left hand of the touch screen.
13. Center the cutting head over the brake rotor as per your lathe’s owner’s manual.

- Using the dial knobs on the cutting head make a light scratch on each side of the rotor while watching the live thickness display on the screen.

Immediately press the “Mark” button in the lower left hand corner of the screen to save the beginning thickness of the rotor. The remaining material that can be removed will be displayed in the lower right hand corner of the screen. **NOTE** "REMAINING -6.11mm" in screen capture to the right»

NOTE: *If you want to save a record and print a report of a rotor which was too narrow, you must make a short cut. Once the 'Cutting in Progress / Stop Cutting' is seen on screen, turn off the motor or move the carbides away from the rotor to cease cutting. Then you will be able to save the data as 'Failed'. A cut must be made to help prevent the use of the Pro-Cut Gyr as a tool for fraudulent 'rotor was too thin to machine' OEM warranty claims. A cut rotor allows for physical audit by OEMs for brake warranty claims. If we did not require the cut, the tool arms could be set to any width and the customer or OEM presented with (false) information that their rotor was too thin to cut.*

If there is not enough material left the screen will turn red and a beeping sound will warn you that the rotor is too thin and you will not be able to proceed with the cut. If the screen is yellow this is a warning to let you know that you are close to the minimum thickness allowed. A green shaded screen means there is still enough material remaining.



- Once you have determined that there is enough material remaining to make a successful cut, advance the cutting head to the inside of the rotor where you will begin the machining process. Set your depth of cut by turning the cutting head knobs clockwise to the desired depth. Each line on the knob represents .001” of depth. We suggest a minimum cut depth of .004”, or 4 lines. Then tighten each cutting arm lock knobs, turn off the lathe motor, install the chip deflector, position the shut off cam, depress the clutch knob and turn lathe motor back on to begin the cut.

SERVICE CORRIDOR CONCEPT CONTINUED

- 16. During the cut, the GPM (gage pick-up module) unit mounted under the cutting head gear box listens for the cut and will cause the “Cut in Progress” alert to be displayed in the yellow command bar.
- 17. Once the cutting tips clear the rotor and the cut is complete the “Cut Completed” message will be displayed in the command bar.

18.

SELECT WHEEL
Press OK to Save:

LF RF
LR RR

OKAY

YEAR 2010
FRONT Police
LAT. RUNOUT
MACHINE-TO DISCARD
APPRO
TO
SAVE RESULT
1
LARGE Connected
VIN

HARGER
ce Pkg
AS CUT STATUS
018 mm ✓
0.31 mm ✓
IMMUM
REMAINING:
5.44

Home, Car, Warning, Info, Help icons

NOTE:
SAVE RESULT
BUTTON

You may select the “save result” button which will bring up the “Select Wheel” dialog box giving you the opportunity to confirm the corner of the vehicle you just completed and allowing you to save the results.

If you do nothing, the “Select Wheel” box will pop up automatically after approximately 30 seconds. The saved data is now displayed on the screen in the appropriate corner of the vehicle. Confirm the correct wheel and select “okay”.

NOTE:
Pressing “Save Result” opens the “SELECT WHEEL” dialog box.

19. Once the first side is complete, move to the other side and complete the second rotor on that axle. You will need to rotate the lathe 180 degrees as per the instructions in the lathe owner's manual.
20. Follow the same process for the second rotor, scratching the rotor, marking the beginning thickness, cutting to the appropriate depth, and saving the results.
21. You may now print the results by touching the "Print" button in the lower left hand corner of the screen. The printed results can now be shared with the customer or can be used for warranty documentation.

OTHER VEHICLE MANUAL ENTRY OF A VEHICLE

If the vehicle does not have a bar code, or you are unable to successfully read the VIN with the scanner, then you can manually enter the vehicle information by selecting year, make, and model from the drop down menus.

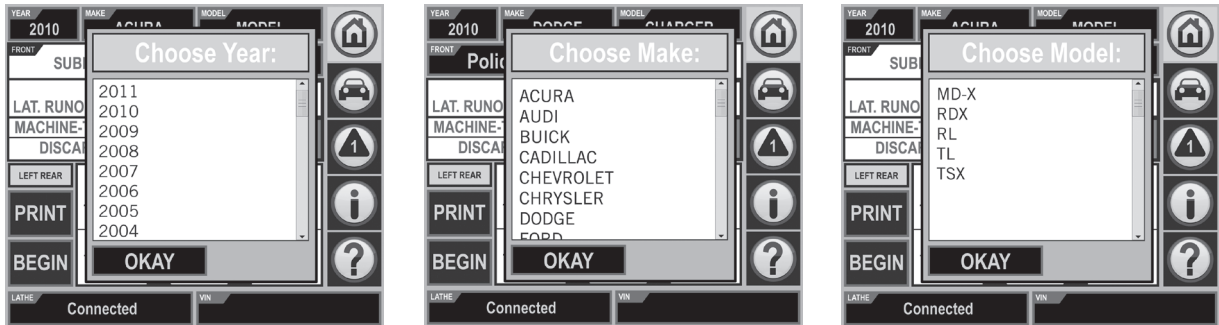

The GYR application not only includes the LRO and thickness specifications, but also includes other needed around the wheel information such as: Tire size, tire pressure, wheel nut torque, brake caliper bolt torque, etc...

MORE FEATURES

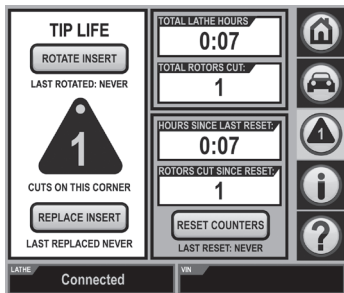

CUTTING TIP LIFE MANAGEMENT

The GYR is also equipped with a tip management application that can help you control expenses by making certain that each tip is completely used. Simply touch the Cutting Tip icon when you change or rotate tips to keep track of their usage and you will be alerted when to change by the flashing tip count icon.

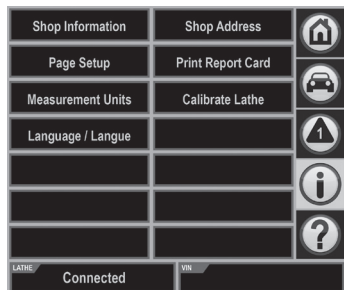

GYR MANAGEMENT CONTROL PANEL

The control panel contains places to update shop information, set up functions, print the report card, and calibrate the cutting head as well as other functions.

Customer Vehicle and Management Reports

As cuts are completed on the vehicle, Adobe Acrobat (.pdf) files are created in the 'Shared Documents' folder on your tablet. As cuts are taken this report is updated. If you need to look up completed jobs, look in this folder. The reports in this folder are the same ones you'd see if you chose 'Print' from the home screen.

Also, there is a Gyr Lathe summary profitability report, which can be accessed by going to the Control Panel screen and choosing 'Print Report Card'. This will let you choose the time period, income and expense values to estimate profits created by using the Pro-Cut Gyr lathe.

Once in this screen you can review the details of all the brake work you have performed by job, and also generate management reports.

The GYR Report Card Contains

- Lathe usage summary
- Cost Assumptions for Front/Rear Jobs
- Totals
- Averages
- ROI (Return On Investment)
- Lathe Health Report

GYR Management Report.

PRO-CUT GYR REPORT CARD					
Prepared For: GW				06/02/2011	
Procut Facility 10 Technology Dr. West Lebanon, NH 03784 USA				(603) 298-5200	
TIME PERIOD AND LATHE(S)					
Time Period			Pro-Cut Lathe(s)		
Last 6 Months			All Lathes		
COST ASSUMPTIONS					
	Front Jobs		Rear Jobs		
Average Cost	\$	25.00	\$	25.00	
Average Revenue	\$	150.00	\$	150.00	
Net Profit	\$	125.00	\$	125.00	
TOTALS					
	Front Jobs		Rear Jobs		Totals
Total Brake Jobs	0		0		0 2-Wheel Jobs
Total Run Time					24.6 Hours
AVERAGES					
	Front Jobs		Rear Jobs		Totals
Avg. Jobs/Week	0.0		0.0		0.0 Jobs
Avg. Lathe Time/Job					0.0 Minutes
PROFIT RETURN ON INVESTMENT					
	Front Jobs		Rear Jobs		Totals
Pro-Cut Profit/Period	\$	0.00	\$	0.00	\$ 0.00 See Note 1
Pro-Cut Profit/Week	\$	0.00	\$	0.00	\$ 0.00
Projected Profit/Year	\$	0.00	\$	0.00	\$ 0.00
PRO-CUT GYR2 HEALTH REPORT					
	Seconds		Status		
Lifetime Avg. Comp Time	20		OK		See Note 2
Last 5 Avg. Comp Time	15		OK		
NOTES					
1) The Pro-Cut lathe will provide the following returns based on weekly usage: <2week=poor ROI, 2-4week=adequate ROI, 5-8week=good ROI, 8+week=excellent ROI.					
2) Average Compensation Times should be less than 60 seconds. If avg. comp time is over 60 seconds, please call your local Pro-Cut rep for service. Avg. comp time should also remain consistent over time. Change in avg. comp time may mean lathe performance is falling. As long as avg. comp time remains less than 60 seconds, the lathe is functioning fine, though a change in avg. comp time of more than 15 seconds should be examined. Please call your Pro-Cut service rep.					
COPYRIGHT ©2008 PRO-CUT USA			PERFECT BRAKE JOB. EVERY TIME.		

TROUBLESHOOTING AND CALIBRATION

GYR is a fast, automated rotor matching system for making in-spec brake repairs while capturing rotor thickness and runout metrics. However, things can go wrong; mistakes can be made. The following troubleshooting guide will help you diagnose issues before you give us a call. If you cannot diagnose your issue after following the troubleshooting guide, please call us at: **1.800.543.6618**

GYR TROUBLESHOOTING GUIDE

ISSUE *LATHE/PC will not communicate. Screen lower left reads "Disconnected." Motor does turn on.*

- TROUBLESHOOT**
1. CHECK ALL WIRING CONNECTIONS. After making sure all are connected, cycle the AC power to the lathe by unplugging it from the wall and plugging it in again.
 2. At the lathe computer box, unplug the USB cable, wait a few seconds and then re-seat the USB cable.

ISSUE *Lathe will not run; computer is on.*

- TROUBLESHOOT**
1. Check power cord connections.
 2. Check shut-off cam.

ISSUE *Scanner will not respond*

- TROUBLESHOOT**
1. Check the scanner's USB cable connections.
 2. Clean vehicle's barcode / windshield.
 3. Vary barcode scanner distance.
 4. Approach barcode with scanner at a 30-degree angle.

GYR TROUBLESHOOTING GUIDE CONTINUED

ISSUE *PC will not print.*

TROUBLESHOOT Check Wi-Fi connectivity. Any network issues should be reported to your internal IT department.

ISSUE *Thickness value of rotor does not change on screen.*

TROUBLESHOOT

1. Check wire connections on cutting head sensor.
2. Check 15-pin connector located on lathe computer for poor connection or damage.
3. Unplug lathe for 15 seconds.
4. Plug back in to reset connections.

CALIBRATION GUIDE

1. Motor must be off but unit plugged in.
2. Computer must be on.
3. Install fresh unused cutting tips on the cutting arms.
4. Select “i” on screen.
5. Select “Calibrate lathe.”
6. Properly place the 0.800" / 20.32mm calibration block between the cutting tips as shown on screen.
7. Select “Okay.”
8. Confirm or press “Yes.”
9. Select “Home.”
10. Remove the calibration block from the cutting arms/tips.
11. Adjust cutting arms out 10 thousandths per arm.
12. Reposition the 0.800" / 20.32mm calibration block between the tips and turn the cutting arms until tips contact the block.
13. The correct thickness (0.800" / 20.32mm) should register on the screen.
 - **If YES**, remove block, clean it and safely store it away.
 - **If NO**, repeat the procedure. Be sure to use the proper orientation of the block when measuring the cutting tip distance.

**Note: There is one pair of faces on the gage block which is NOT 0.800".
Be very careful to not use this pair when calibrating the cutting head.*

For Tech Support, call 800.543.6618. Press #2 for service.

ATTENTION

A .8" calibration block is required to perform this procedure.

6 8 ADAPTER PACKAGES



50-687

4-HOLE ADAPTER
Fits most 4-lug vehicles.

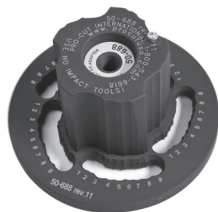

50-688

5-HOLE ADAPTER
Fits most smaller 5-lug vehicles.



50-695

SMALL TRUCK/LARGER CAR ADAPTER
Fits many small trucks and SUV's as well as larger passenger cars.



50-691

1/2-TON TRUCK ADAPTER/COMMON
Fits most pickups and sport utility vehicles.



50-681

TOYOTA SPECIALTY & ALTERNATE TRUCK ADAPTER

Fits most pickups and SUVs including the Toyota Land Cruiser and VW Touareg (does NOT have common Ford pattern found on the 50-691 adaptor).



50-694

TALL HUB TRUCK ADAPTER

Primarily used to fit the 2003+ Expedition and 2004+F150, this adapter shares patterns with other common trucks that have tall hubs which may interfere with the 50-691 adapter.



50-683

3/4 TON TRUCK ADAPTER/COMMON

Fits most 3/4 ton single wheel trucks front and rear.



50-935

DUAL WHEEL TRUCK ADAPTER

Fits 1-ton Ford, Dodge, and Chevy trucks and vans with dual wheels.

X9 PARTS DIAGRAM 50-2200 X9 LATHE BODY

ITEM NO.	PART NUMBER	QTY.
1	50-2201	1
2	50-2202	1
3	50-1831	1
4	50-2218	1
5	50-566	1
6	50-570	1
7	50-565	1
8	50-1400	1
9	50-1804	1
10	50-1184	1
11	50-2220	1
12	50-143	1
13	50-1824	1
14	50-2211	1
15	50-1142	1
16	50-560	1
17	50-2223	1
18	50-2208	1
19	50-2242	1
20	50-861	1
21	50-1845	1
22	50-1846	1
23	37-1854	1
24	37-1805	1
25	37-1845	1
26	50-2239	1
27	37-2208	1
28	37-156	3
29	37-157	3
30	35-800	3
31	35-838	3
32	35-414	2
33	35-834	3
34	37-025	3
35	35-317	4
36	37-003	4
37	36-002	4
38	35-278	1
39	37-025	2
40	35-926	3
41	35-835	2
42	35-280	6
43	35-281	2
44	35-811	2
45	37-274	4
46	36-010	4
47	37-1808	1
48	50-567	1
49	50-2217	1
50	37-117	1
51	35-837	1

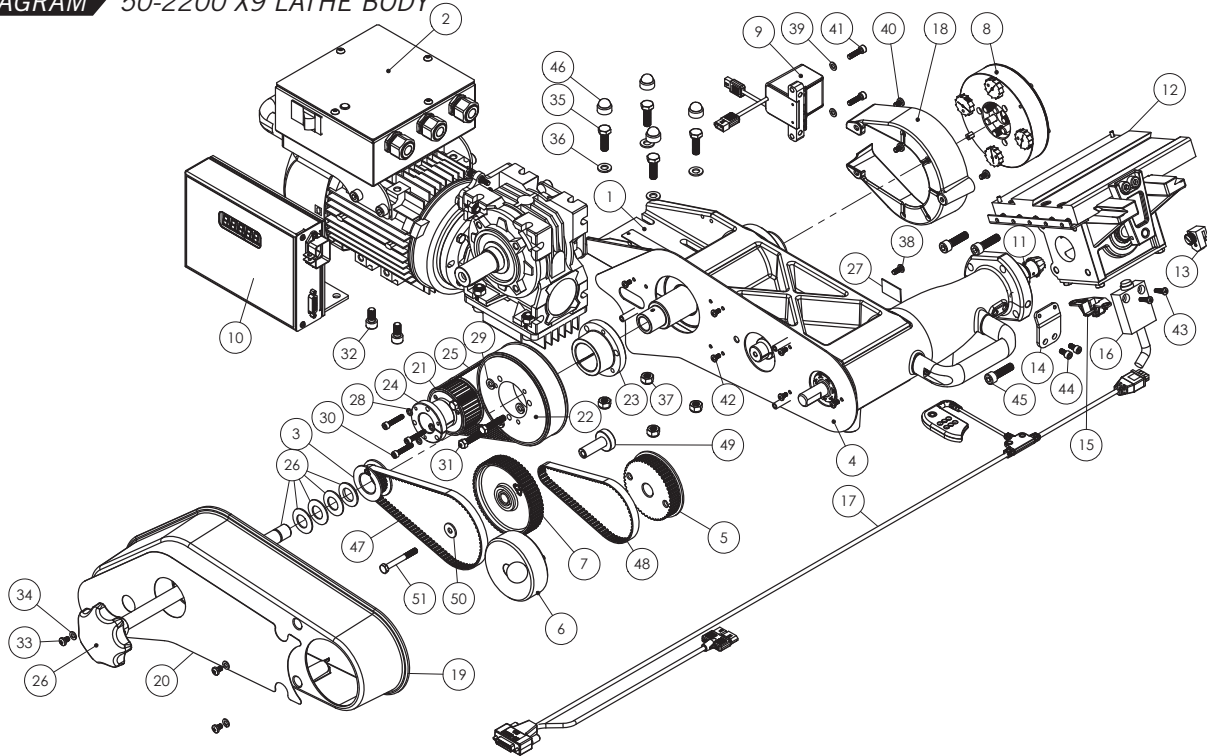

X9 PARTS DIAGRAM 50-220 CUTTING HEAD

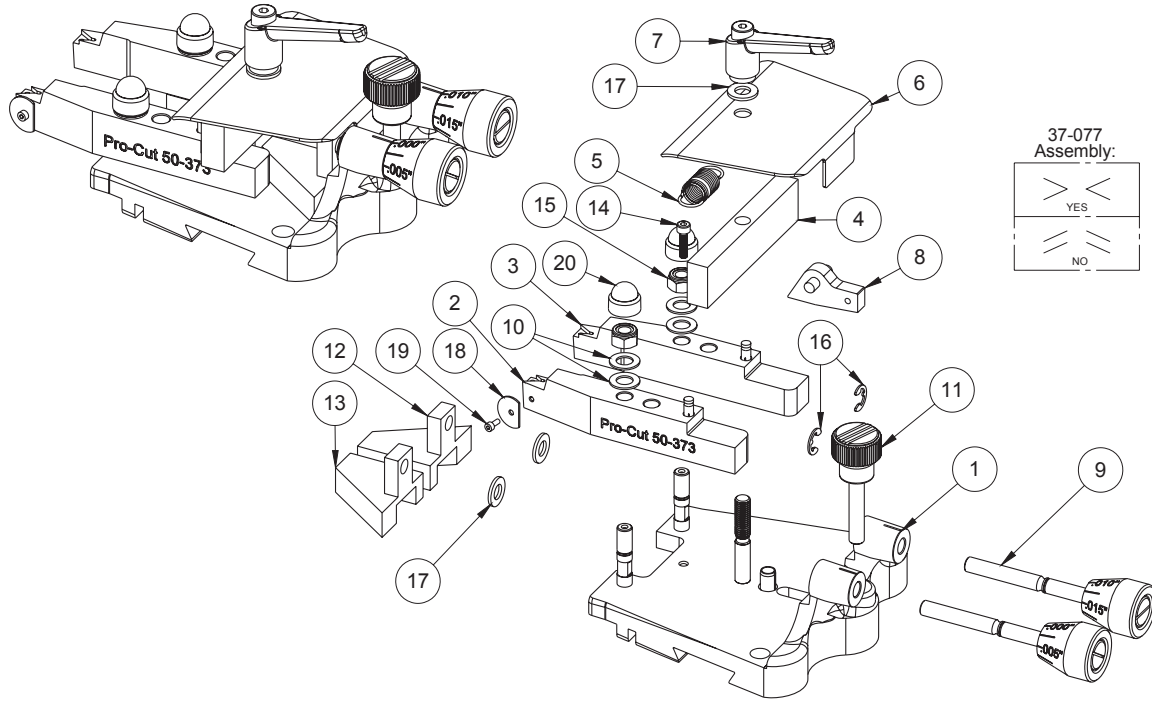

37-077
Assembly:

YES

NO

ITEM NO.	PART NUMBER	QTY
1	50-293	1
2	50-373	1
3	50-374	1
4	50-252	1
5	50-053	1
6	50-250	1
7	37-473	1
8	50-249	1
9	50-098	2
10	37-077	4
11	37-812	1
12	50-253	1
13	50-254	1
14	35-259	1
15	36-002	2
16	37-082	2
17	37-003	3
18	50-365	1
19	50-364	1
20	36-010	2

10/15/2009

X9 PARTS DIAGRAM 50-139 BEVEL GEAR BOX

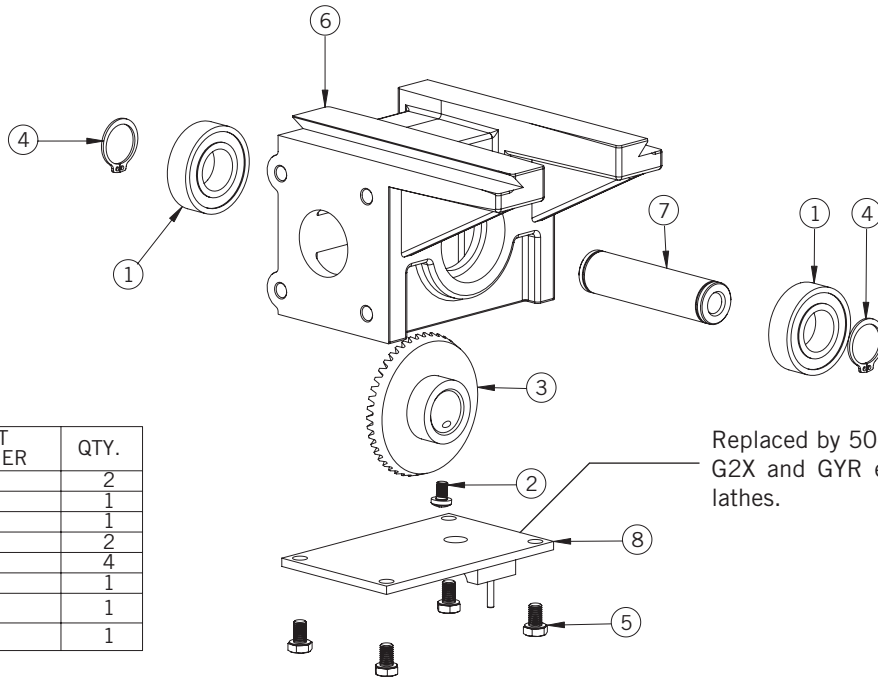

ITEM NO.	PART NUMBER	QTY.
1	37-056	2
2	35-928	1
3	50-021	1
4	37-057	2
5	37-927	4
6	50-014	1
7	50-016	1
8	50-039	1

Replaced by 50-1148 in G2X and GYR equipped lathes.

X9 PARTS DIAGRAM PRO-CUT 50-2195 TROLLEY

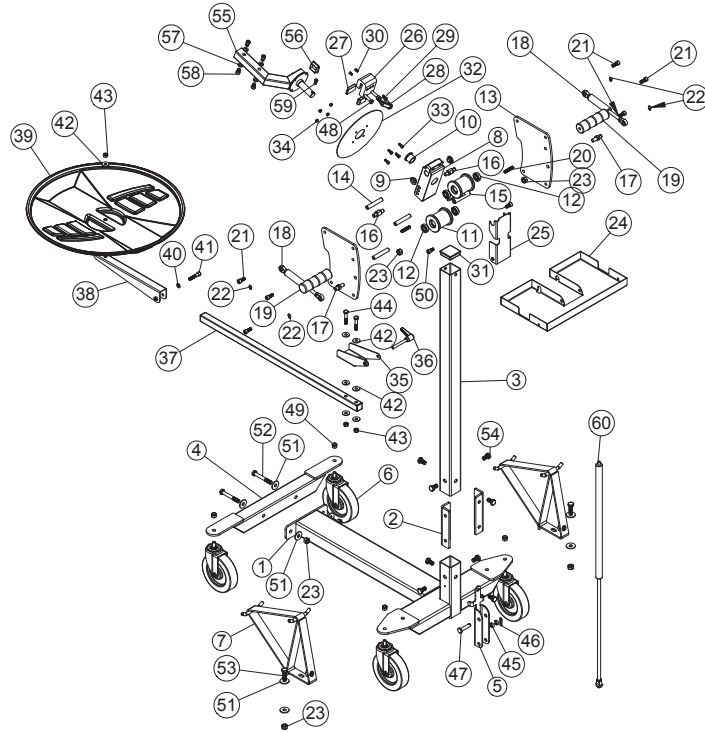

ITEM NO.	PART NUMBER	QTY.
1	50-2023	1
2	50-2026	1
3	50-2028	1
4	50-2028	1
5	50-2028	1
6	37-032	4
7	50-2030	2
8	50-2073.1	1
9	37-304	2
10	37-305	2
11	50-2072.1	2
12	37-064	4
13	50-2071	2
14	50-2076	4
15	50-2016	1
16	50-2074	2
17	50-2075	2
18	37-485	2
19	50-1032	2
20	37-721	2
21	35-283	6
22	37-498	4
23	36-001B	6
24	50-2077	1
25	50-2078	1
26	50-1061	1
27	50-1062	2
28	37-1065	1
29	35-307	2
30	35-815	2
31	37-618	1
32	50-2034	1
33	35-292	4
34	36-172	4
35	50-2041	1
36	37-484	1
37	50-2042	1
38	50-2043	1
39	50-2044	1
40	37-011	1
41	35-293	1
42	37-111	7
43	36-002	3
44	35-282	2
45	50-2014	2
46	37-496	1
47	37-748	1
48	35-425	2
49	36-001A	4
50	35-414	4
51	37-993	8
52	35-338	2
53	35-304	2
54	35-275	8
55	50-1828	1
56	37-617	1
57	37-003	4
58	35-288	4
59	35-284	1
60	37-489	1

X9 PARTS DIAGRAM PART NO. 50-1148

ITEM NO.	Part Number	QTY.
1	50-1155	1
2	50-1127	1
3	50-1149	1
4	35-258	6

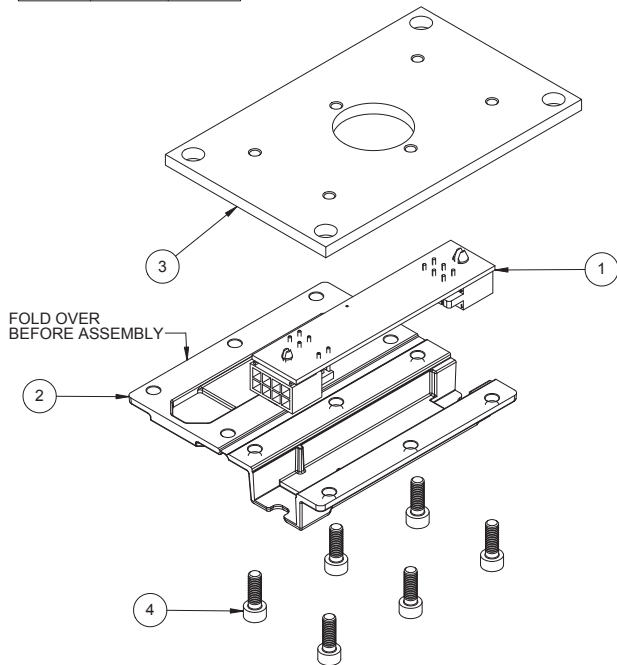

X9 PARTS DIAGRAM PART NO. 50-1190

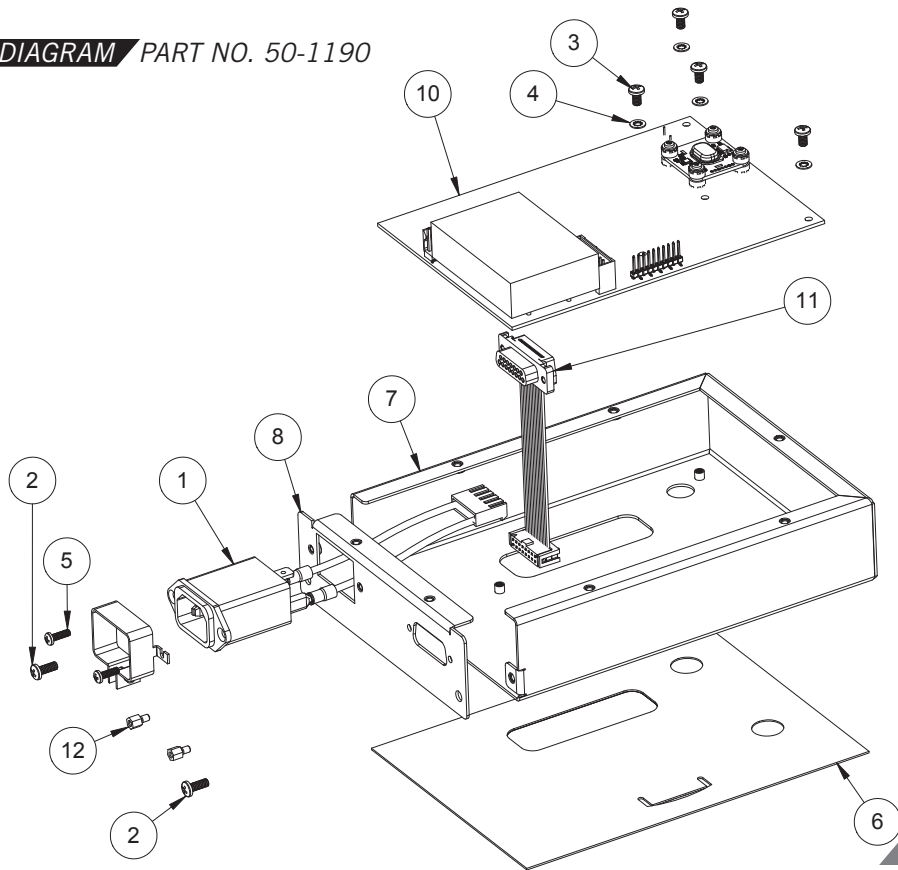

50-1190

ITEM NO.	PART NUMBER	QTY.
1	50-457	1
2	35-806	2
3	35-311	4
4	37-016	4
5	35-802	2
6	50-1135	1
7	50-1128	1
8	50-1125	1
9	37-628	1
10	50-1154	1
11	50-1144	1
12	35-418	2

X9 PARTS DIAGRAM PART NO. 50-1250 (G2X / GYR PACKAGE)

ITEM NO.	Part Number	QTY.
1	50-1211	1
2	50-1228	1
3	35-257	1
4	35-284	8
5	50-1256	1
7	50-1259	1
8	50-1261	2
9	50-1254	2
10	37-076	4
11	35-291	8
12	35-815	4
13	50-1264	2
14	37-1220	2
15	37-454	3
16	35-818	2
17	38-025	2
18	37-1250	4
19	37-614	4
20	35-926	4
21	50-1252	1
22	35-318	4
23	37-159	4
24	37-087	2
25	50-742	2
26	50-364	2
27	50-1257	1
28	50-1258	1
29	50-1253	1
30	50-1213.1	1
31	37-1202	6
32	50-1212.1	1
33	50-1230	1
34	50-1231	1
35	50-1232	1
36	50-1214	2
37	35-928	4
38	50-1245	2
39	50-1238	1
40	36-024	4
41	35-298	2
42	35-718	3
43	35-717	3
44	37-1203	4
45	50-1229	1
46	50-1215	1
47	37-1224	1

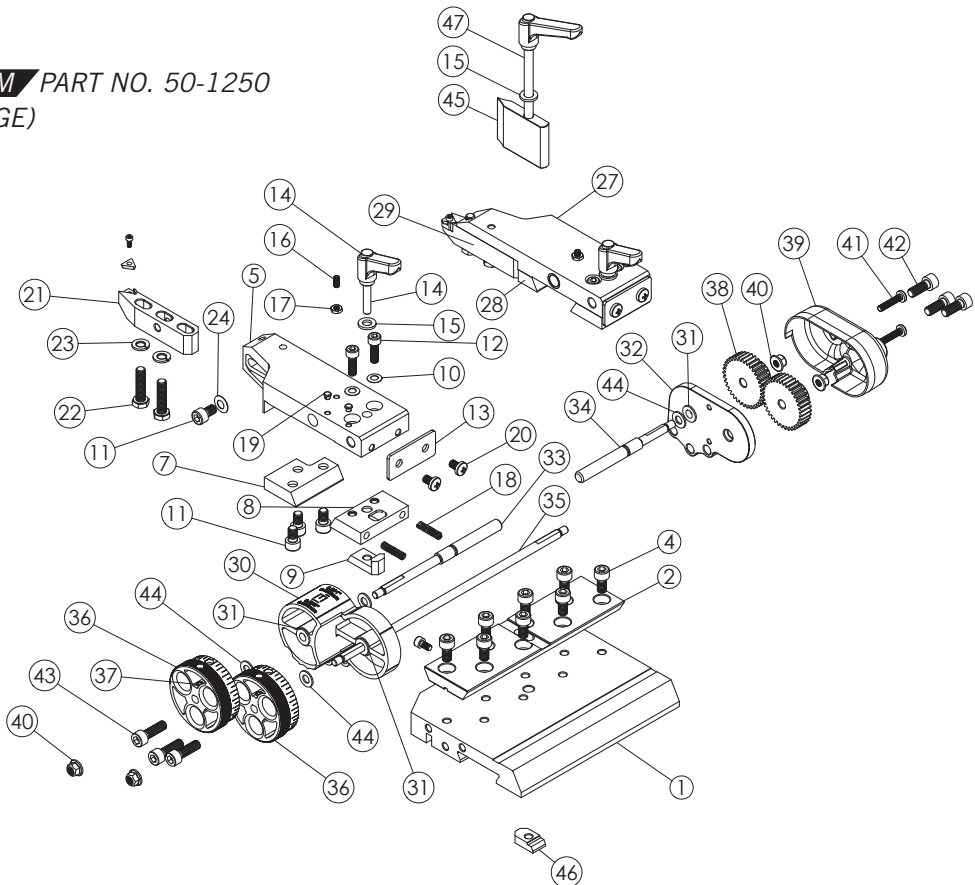

X9 PARTS DIAGRAM PART NO. 50-1206

(G2X / GYR PACKAGE)

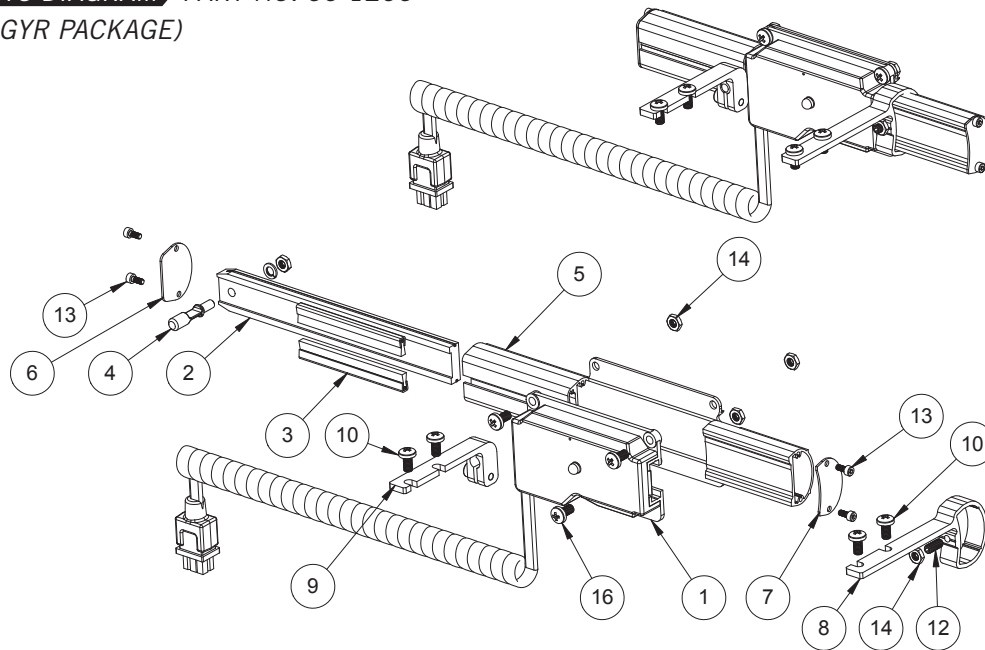

ITEM NO.	Part Number	QTY.
1	50-1145	1
2	50-1146	1
3	50-1221	2
4	50-1244	1
5	50-1239	1
6	50-1242	1
7	50-1243	1
8	50-1241	1
9	50-1240	1
10	35-303	4
11	35-270	1
12	35-296	1
13	35-295	4
14	36-025	5
15	37-019	1
16	35-280	3

7/13/2011

X9 PARTS DIAGRAM PRO-CUT SPINDLE GUARD

ITEM NO.	PART NUMBER	DESCRIPTION	QTY.
1	50-1741	9.2 Lathe Guard Weldment	1
2	35-275	Hexagon head screw ISO 4017 - M10 x 20	1
3	37-1730	B18.22M - Plain washer, 10 mm, Wide, Steel, Bright Zinc	1

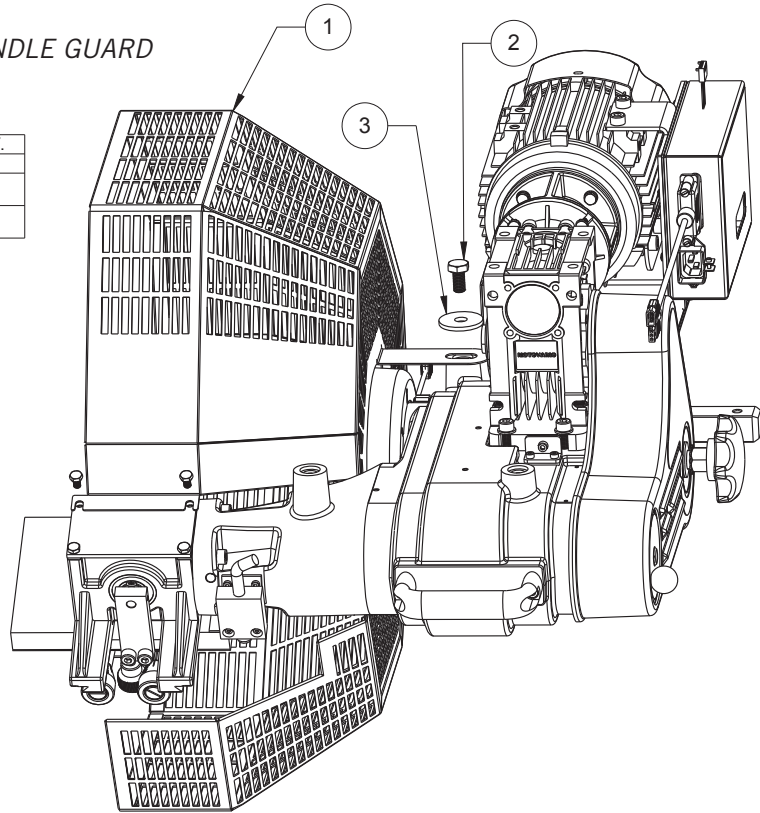

X9 PARTS DIAGRAM BEVEL GEAR BOX

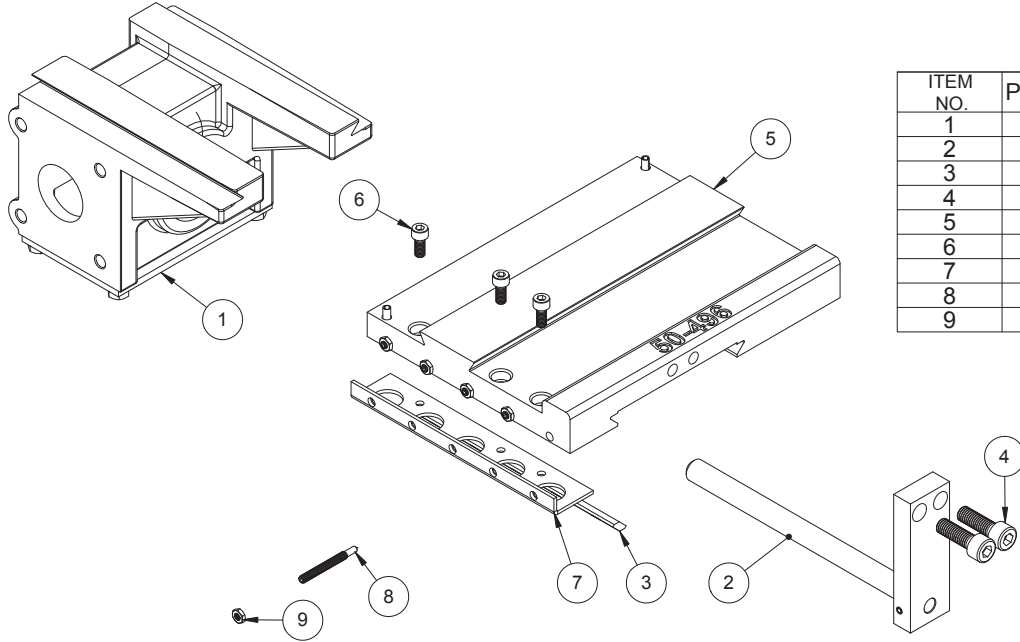

ITEM NO.	PART NUMBER	QTY.
1	50-139	1
2	50-034	1
3	50-463	1
4	35-236	2
5	50-496	1
6	35-235	3
7	50-075	1
8	35-934	5
9	36-019	5

X9 PARTS DIAGRAM PART NO. 50-1360 (GYR PACKAGE)

ITEM NO.	PART NUMBER	QTY.
1	50-1351	1
2	50-1352	1
3	50-1353	1
4	50-1354	1
5	50-1355	1
6	37-1356	1
7	37-1355	1
8	36-019	4
9	35-310	4
10	37-111	2
11	36-002	1
12	36-021	4
13	35-806	2
14	37-1358	6
15	37-1357	2

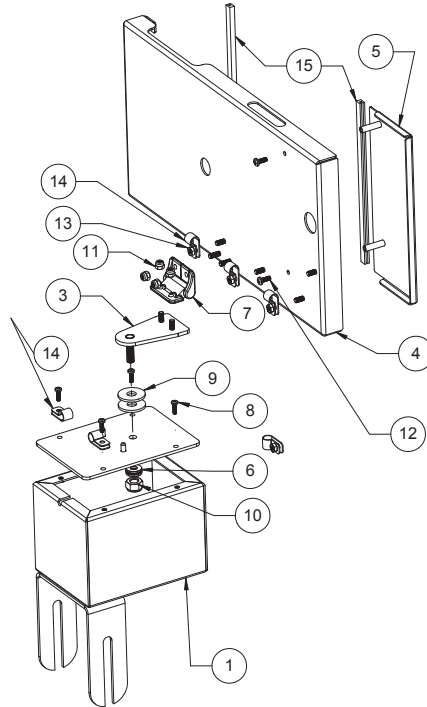

Not Shown:		
Part No.	Qty	Description
37-1100	1	PC - CUSTOMIZED WITH SPECIAL IMAGE
50-613	1	Power Cord - 25' Straight 5-15P / Stripped & Crimped
37-1812	1	USB Cable - A to B 6
50-1139	1	USB A to DATALOGIC Scanner Cord, Coil Type
37-1831	2	Ferrite for USB Cable
37-1832	1	AC Power Ferrite
37-1819	1	USB Bar Code Scanner

X9 PARTS DIAGRAM PART NO. 50-2202

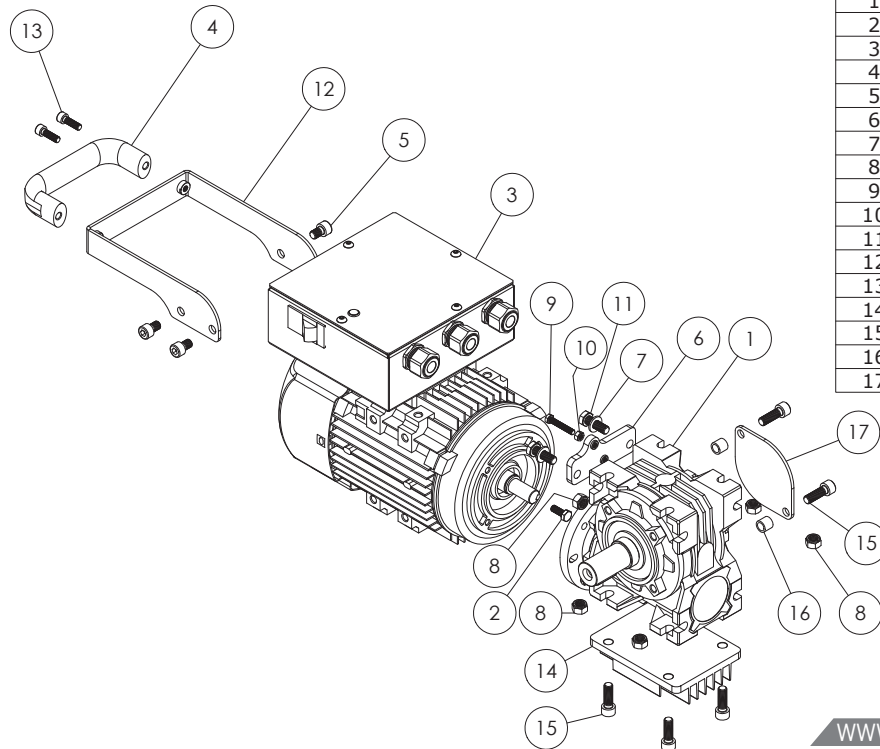

ITEM NO.	PART NUMBER	QTY.
1	37-2200	1
2	35-364	4
3	50-546	1
4	37-813	1
5	35-289	4
6	50-2207	1
7	37-003	2
8	36-002	6
9	35-320	1
10	36-173	1
11	35-317	2
12	50-1834	1
13	35-717	2
14	50-2209	1
15	35-236	6
16	50-2243	2
17	50-2244	1

MAINTENANCE SCHEDULE

<i>DATE</i>	<i>NOTES</i>	<i>DRO READINGS</i>			
		HOURS	TOTAL	AVERAGE	LAST 5
MONTH / DAY / YEAR					

MAINTENANCE SCHEDULE

DATE MONTH / DAY / YEAR	NOTES	DRO READINGS			
		HOURS	TOTAL	AVERAGE	LAST 5



Pro-Cut International, LLC
10 Technology Drive #4
West Lebanon, NH 03784

P. 800.543.6618 / 603.298.5200

F. 603.298.8404

E. info@procutusa.com



Global inquiries please see:
www.procutusa.com