

Contact your Rotunda area Sales Manager
or your Field Service Engineer
1-800-ROTUNDA www.OneRotunda.com

FASTJACK® 71500E
5 TON CAPACITY

FASTJACK® 71550E
5 TON CAPACITY
(Air & Hydraulic)

INTENDED USE

Truck fleet, truck and farm
equipment dealers and bus
company garages.

FEATURES

- Chromed ram and dust seals prevent hydraulic contamination.
- Safety by-pass and overload systems protect hydraulic block.
- Air pump models can also be operated manually.
- All models except for the 72230A include the FASTJACK® feature which raises the jack's lifting saddle to the load with one pump of the "T" handle.
- Locking release lever secures handle in the vertical, 45 degree or horizontal position to lower the load on all models.

***NOTE:**

Models not shown have same basic construction as models pictured.

FASTJACK® 71000D
10 TON CAPACITY

FASTJACK® 71100A
10 TON CAPACITY
(Air & Hydraulic)

FASTJACK® 72220A
20 TON CAPACITY

72230A

20 TON CAPACITY
(Air & Hydraulic)

INTENDED USE

Heavy duty truck, heavy
construction and agricultural
equipment maintenance garages.



FASTJACK® mechanism raises the jack's lifting saddle to the load in one pump stroke.

U.S. PATENT NUMBER: 7,055,801 B2

71500E (shown)
***71550E**

***71000D**
71100A (shown)

***72220A**
72230A (shown)

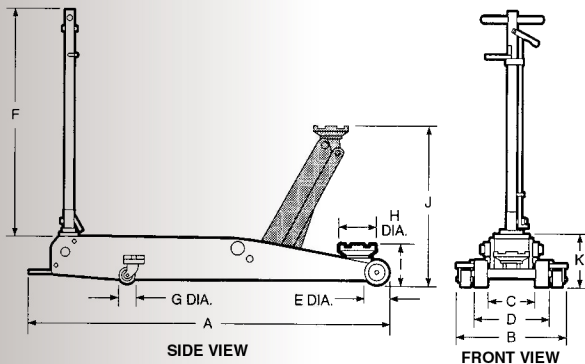
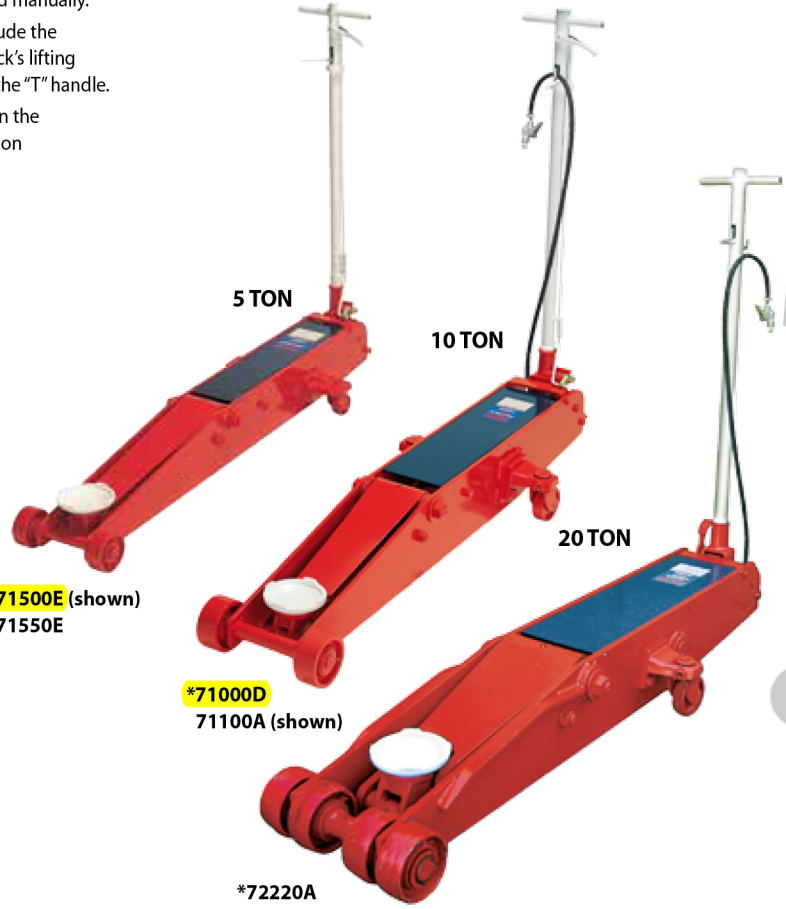

MODEL NUMBER	CAPACITY	A	B	C	D	E	F	G	H	I	J	K	SHIPPING WEIGHT (Lbs.)
71500E	5 TON	62.25"	16.75"	6.75"	11.75"	4.25"	40"	2.75"	6.25"	5.625"	27.25"	7.875"	270
71550E	5 TON @ 120 P.S.I.	62.25"	16.75"	6.75"	11.75"	4.25"	40"	2.75"	6.25"	5.625"	27.25"	7.875"	270
71000D	10 TON	68.5"	21"	9"	14.5"	5.5"	46.75"	4.375"	6.5"	6.125"	27.25"	9.75"	455
71100A	10 TON @ 120 P.S.I.	68.5"	21"	9"	14.5"	5.5"	46.75"	4.375"	6.5"	6.125"	27.25"	9.75"	466
72220A	20 TON	71.5"	20.75"	10.125"	16"	5.5"	45"	4"	6.5"	7.25"	26.25"	9.625"	650
72230A	20 TON @ 120 P.S.I.	71.5"	20.75"	10.125"	16"	5.5"	45"	4"	6.5"	7.25"	26.25"	9.625"	670