

Road Force® Elite Wheel Balancer

HUNTER
Engineering Company

SPECIFICATIONS



RFE13™ Shown

Power Requirements	196-253V, 10 amp, 50/60 Hz, 1 ph NEMA L6-20P plug included
Air Supply Requirements	100-175 psi (7-12 bar)
Roller Force	Variable up to 1,250 lbs (567 kg)
Rim Width Range	1.5 in to 20.5 in (38 mm to 521 mm)
Rim Diameter Range	10 in to 30 in (254 mm to 762 mm)*
ALU	14 in to 40 in (356 mm to 1016 mm)*
Max. Tire Diameter	40 in (1016 mm)
Max. Tire Width	20 in (508 mm)
Max. Tire Weight	175 lbs (79 kg)
Radial & Lateral Runout Accuracy	0.002 in (0.051 mm)
Imbalance Resolution	± 0.01 oz (0.28 g)
Placement Accuracy	512 positions, ± 0.35°
Balancing Speed	300 rpm
Motor	Programmable drive system and DC motor

* Extreme wheel sizes may require manual data entry.

MODEL FEATURES / DIMENSIONS**

	RFE33	RFE32	RFE31	RFE30	RFE23	RFE22	RFE21	RFE20	RFE13	RFE12	RFE11	RFE10	RFE03	RFE02	RFE01	RFE00
Wheel Lift	✓	✓	✓	✓					✓	✓	✓	✓				
SpeedClamp®	✓	✓	✓	✓	✓	✓	✓	✓								
TDC Laser†	✓	✓			✓	✓			✓	✓			✓	✓		
Printer & Shelf	✓		✓		✓		✓		✓		✓		✓		✓	
Width (W)	72 in. 1829 mm	64 in. 1626 mm	72 in. 1829 mm	64 in. 1626 mm	65 in. 1651 mm	57 in. 1448 mm	65 in. 1651 mm	57 in. 1448 mm	72 in. 1829 mm	64 in. 1626 mm	72 in. 1829 mm	64 in. 1626 mm	65 in. 1651 mm	57 in. 1448 mm	65 in. 1651 mm	57 in. 1448 mm
Height (H)	89 in. 2261 mm	89 in. 2261 mm	70 in. 1778 mm	70 in. 1778 mm	89 in. 2261 mm	89 in. 2261 mm	70 in. 1778 mm	70 in. 1778 mm	89 in. 2261 mm	89 in. 2261 mm	70 in. 1778 mm	70 in. 1778 mm	89 in. 2261 mm	89 in. 2261 mm	70 in. 1778 mm	70 in. 1778 mm
Depth (D)	63 in. 1600 mm	63 in. 1600 mm	63 in. 1600 mm	63 in. 1600 mm	63 in. 1600 mm	63 in. 1600 mm	63 in. 1600 mm	63 in. 1600 mm	63 in. 1600 mm	63 in. 1600 mm	63 in. 1600 mm	63 in. 1600 mm	63 in. 1600 mm	63 in. 1600 mm	63 in. 1600 mm	63 in. 1600 mm
Weight	928 lb 421 kg	876 lb 397 kg	873 lb 396 kg	821 lb 372 kg	829 lb 376 kg	777 lb 352 kg	774 lb 351 kg	739 lb 335 kg	928 lb 421 kg	876 lb 397 kg	873 lb 396 kg	821 lb 372 kg	829 lb 376 kg	777 lb 352 kg	774 lb 351 kg	722 lb 327 kg

**Road Force® Elite model numbers are trademarks of Hunter Engineering Company

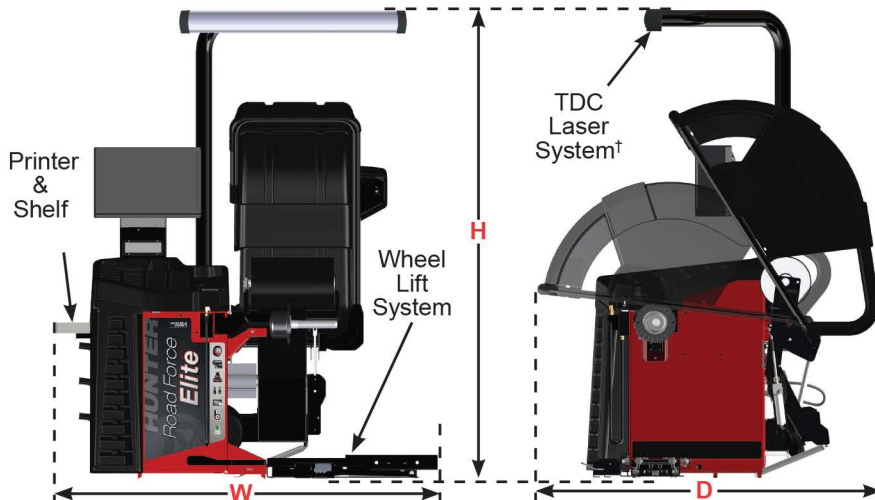

www.OneRotunda.com
1.800.ROTUNDA

Contact your Field Service Engineer
or
Rotunda Area Sales Manager

Because of continuing technological advancements, specifications, models and options are subject to change without notice.

The Road Force® Elite Wheel Balancer is a Class 1 laser product.

† When equipped with the TDC system, the balancer is a Class 2M laser product.

⚠ LASER RADIATION - DO NOT STARE INTO THE BEAM OR VIEW DIRECTLY WITH OPTICAL INSTRUMENTS.
Viewing the laser output with magnifiers or related optical instruments within a distance of 100 mm from the laser aperture may pose an eye hazard

Form 7103-T, 04-16
Copyright © 2016, Hunter Engineering Company