

L454/454L

Closed Front 4-Post Lift Rack

SPECIFICATIONS

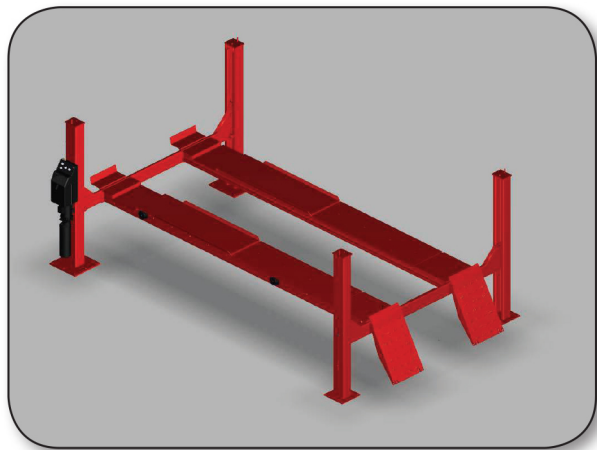

L454 Closed Front 4 Post Lift

Site Specifications	
Power Requirements	208-230 VAC, single phase power, 26 Amp
Air Supply Requirements	90-150 PSI (6.2-10.3 bar)
Minimum Concrete Spec.	4 in. (102 mm) thick, 3000 PSI (20,700kPA) rating
Maximum Floor Variation	3 in. (76 mm) between any two posts
Product Specifications	
Max. Vehicle Weight	18,000 lbs. (8164 kg)
Max. Wheelbase	
General Service	L454: 193 in. (4902 mm) L454L: 227 in. (5766 mm)
Two-Wheel Alignment	L454: 177 in.* (4496 mm) L454L: 211 in.* (5360 mm)
Four-Wheel Alignment	158 in. (4013 mm)
Alignment Height	Any of 16 lock positions
Min. Four-Wheel Alignment	88 in. (2235 mm)
Lifting Speed	64 seconds
Lowering Speed	40 seconds

* Jacking compensation may be required to align some long wheelbase vehicles.

MODEL FEATURES / DIMENSIONS / OPTIONS

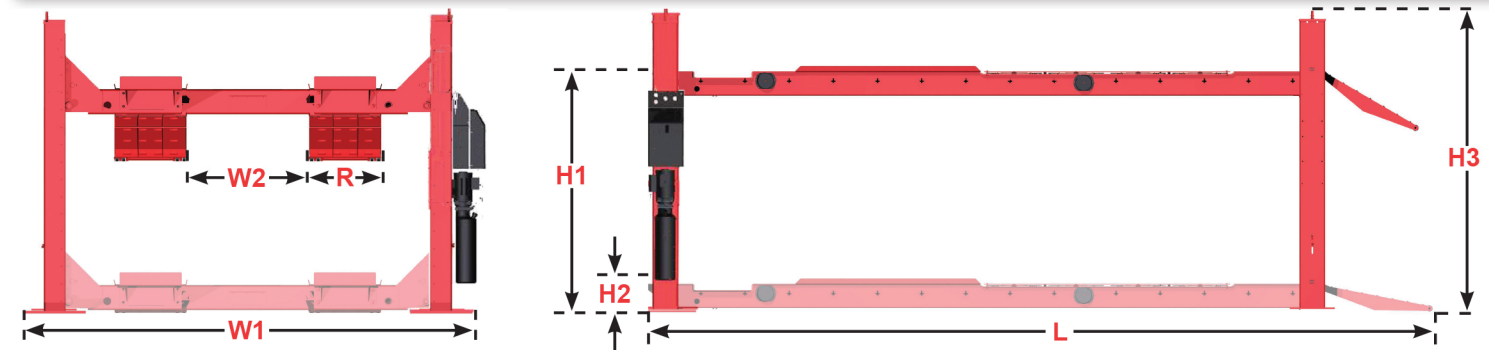

Features	JT	T-PS	T-IS
9000-lb Swing Air Jacks (2)	✓	✓	✓
POWER SLIDE		✓	✓
INFLATION STATION			✓
FIA Fully Integrated Alignment			✓

Dimensions	
Width (W1)	139.25 in. 3537 mm
Inside Width (W2)	40 in. 1016 mm
L454 Length (L)	255 in. 6477 mm
L454L Length	287.5 in. 7303 mm
Runway Width (R)	22.5 in. 572 mm
Runway Height (H1)	75 in. 1905 mm
Stack Height (H2)	8.75 in. 222 mm
Post Height (H3)	98 in. 2489 mm

Options	Add. Length	Kit #
Approach Ramp Extension	17.5 in. 445 mm	20-1365-1
Extended Approach Ramp Extension	40 in. 1016 mm	20-2033-1
Drive Thru Kit	38 in. 965 mm	20-2682-1
Front Mount Power Unit Bracket	-	20-3072-1
Rack Lighting	-	20-2993-1



Contact your Rotunda area Sales Manager or your Field Service Engineer

1-800-ROTUNDA

www.OneRotunda.com

Continued on Page 2



L454/454L

Closed Front 4-Post Lift Rack

SPECIFICATIONS

L454 AND L454L DIMENSIONS / L454L ILLUSTRATED

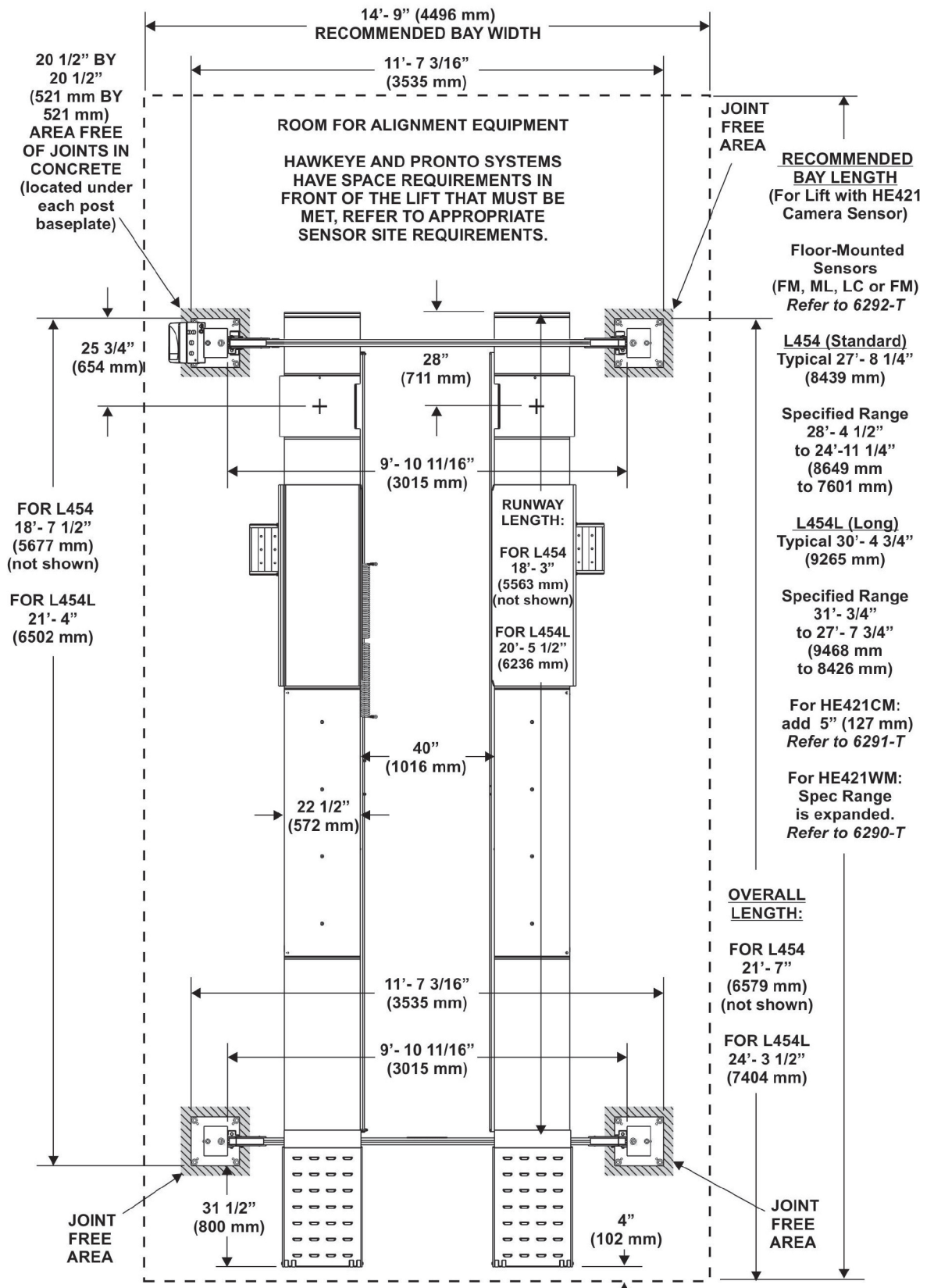

*If installing over basement or near seams and cracks, refer to Form 4963-T. For exact placement of lag bolts, refer to Form 6530-T.