



CHIEF

GO LIATH™



LINCOLN

ROTUNDA

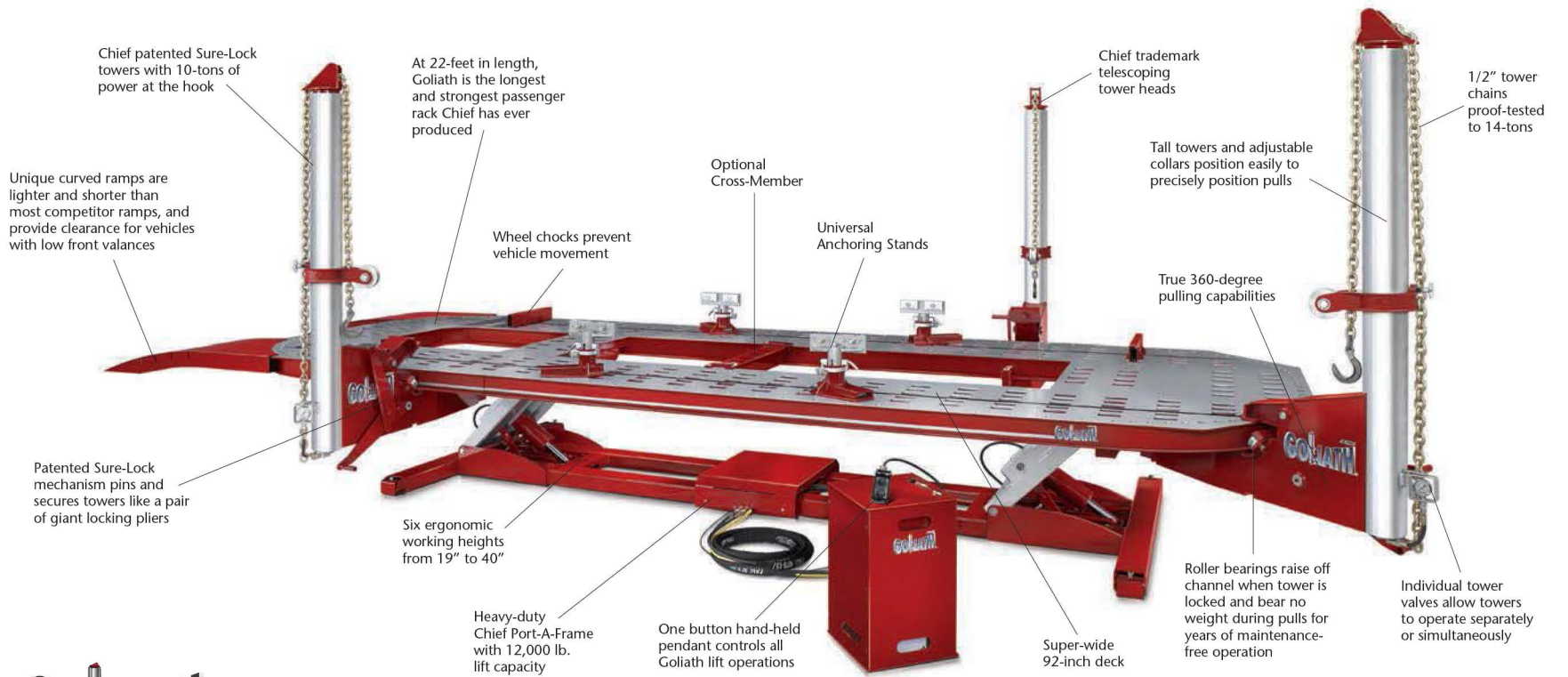

Specifications

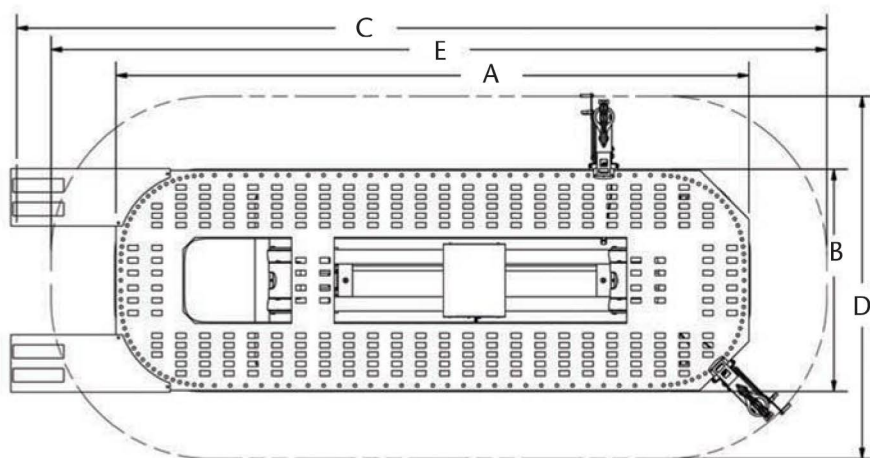

FEATURE

SPECIFICATION

A. Deck Length	22'	(6,706mm)
B. Deck Width	7' 9"	(2,362mm)
C. Maximum Length (Footprint)	28' 6"	(8,687mm)
D. Maximum Width (Footprint)	12' 7"	(3,835mm)
E. Maximum Working Length (w/ Tower)	27'	(8,230mm)
Maximum Height	9' 10"	(3,028mm)
Working Heights (Floor To Top Of Deck)	6 Stops: 19"- 40"	(483mm-1,016mm)
Weight (2 Tower)	7,100 lbs.	(3,220 kg)
Weight (3 Tower)	7,750 lbs.	(3,515 kg)
Lift Capacity	12,000 lbs.	(5,443 kg)
Pulling Force Per Tower	10-Ton	(89kN)
Tie-Down Openings (With Cross-Member)	280	
Power	115v, 50/60Hz, Single Phase or 230v, 50/60Hz, Single Phase	

Optional Accessories



Deluxe Chain and Clamp Accessory Package

You can't do the job right without the right tools. Choose Chief's Deluxe Chain and Clamp Accessory Package or one of 10 other tool board configurations designed to match a wide range of budgets and needs. *Part #697150*



Sure-Lock Handle Extension

Specifically engineered handle extension makes locking and unlocking of Sure-Lock towers quick and incredibly easy. *Part #450510*



Goliath provides all the size, power and quality performance you need to repair today's larger vehicles, and is value-priced to insure a speedy return on your investment.



Auxiliary Rams

Enhance your pulling and lifting capabilities with Chief's rugged and durable auxiliary rams. *4" Ram Part #450479*
6" Ram Part #450441



FAST Anchoring

Techs love Chief's FAST anchoring system because it's versatile, easy to use and gets the job done fast. *Part #200033*

Call today to find out more!

The best just got BIGGER!



Never turn away business because of an undersized rack again. At 22-feet long and 92-inches wide, Goliath can easily handle the biggest and baddest pick-ups and SUVs around, and is the longest and strongest passenger car and truck frame pulling system Chief has ever produced!

GOLIATH

CHIEF
automotive technologies

© 2012 VEHICLE SERVICE GROUP™. Printed in the U.S.A. All Rights Reserved. Unless otherwise indicated, CHIEF AUTOMOTIVE TECHNOLOGIES, VEHICLE SERVICE GROUP™, DOVER and all other trademarks are property of the Dover Corporation and its affiliates. Chief Automotive Technologies reserves the right to alter product specifications and/or package components without notice, excluding changes to components subject to FCC & IC regulations.

GOL Revise 09/2012 (SUPERSEDES GOL 04/10)



Pound For Pound The Best Rack Chief® Has Ever Produced

Look down any street and you'll see when it comes to their vehicles, Americans believe "bigger is better." And typically, the bigger the vehicle, the more profitable the repairs.

With the glut of super-sized vehicles on the road today, you need a pulling system that can handle them all. Goliath™ was engineered to give you the size, power and flexibility to quickly, easily and profitably repair any sized passenger vehicle on the market today.

Plus, like all Chief® products, your Goliath includes the quality materials, skilled craftsmanship, low maintenance and on-going service and support needed to insure that it will be outperforming and intimidating the competition for years to come.



Nothing It Can't Handle

At 22-feet in length and 92-inches wide, Goliath can accommodate the largest passenger vehicles with room to spare.



Now That's What I'm Talking About!

Goliath features Chief 10-ton towers with the patented Sure-Lock clamping system, and rugged 1/2-inch tower chains that are proof tested to 14-tons.



Simultaneous Pulls? No Sweat!

Goliath is creatively engineered to afford 360-degree pulling anywhere around the deck perimeter, allowing for ganging of towers and simultaneous multiple pulls.



A True Power Lifter

Goliath's innovative lift mechanism can effortlessly lift a whopping 12,000 pounds, and its six variable working heights provide easy and ergonomically beneficial access.



High Performance. Low Maintenance.

Goliath's tower bearings roll when tower is locked and no weight during pulls so cannot be damaged during normal use. And bearings are lubrication free and easily cleaned with just compressed

Tale Of The Tape

Not convinced Goliath is as big and bad as advertised? Prove it yourself. Compare Goliath's specs below with any rack on the market today. Then compare Goliath's low price and impressive capabilities with those same competitors. We think you'll be in for a very BIG and pleasant surprise.

10-Tons Of Power At The Hook
12,000 Pound Lift Capacity
Variable Deck Heights From 19"-40"

FEATURE	GOLIATH
Pulling Force Per Tower	10-Tons At The Hook (not just 10-Ton rams)
Lift Capacity	12,000 lbs.
Simultaneous Multiple Pulling	Yes
True 360-Degree Capabilities	Yes
Variable Height.....	Six Heights From 19"-40"
Self-Leveling Deck	Yes
Ability To Gang Towers Anywhere	Yes
All Functions Controlled From Single Hand-Held Pendant.....	Yes
Tower Materials	5/16" And 3/8" High-Strength Steel
Tower Chains	1/2" Proof Tested To 14-Tons At The Hook
Tower Ram	10-Inch Stroke, 10-Tons Of Pull
Tower Rollers	4 Per Tower
Tower Bearings.....	Tapered, Non-Lubricated
Deck Plating	A-572 Steel — Single Piece Temper Pass
Deck Plate Strength.....	50,000 PSI Yield
Deck Tolerance020 Inches
Deck Leveling Points	3 On Each End, Six Total
Tie-Down Openings	280 (With Cross-Member)
Powder Coated Components	Yes
Training Available	Yes
Service Available.....	Yes
Technical Support Available.....	Yes

Available Configurations:..... 20 Series (2 Towers)
 30 Series (3 Towers)
 40 Series (4 Towers)



The One And Only

Just one button controls the lift system and all up and down deck movement.



The Pressure's On

Goliath's individually mounted pressure gauges and shut-off valves keep clutter to a minimum, and all hydraulic hoses have a 20,000 lbs. burst point with a 4-to-1 safety factor (twice the industry standard of 2-to-1).

ce.
 ce.
 ngs raise
 and bear
 ls so they
 during
 rings
 and easily
 mpressed air.