

# Challenger Lifts

## **Stay Dry™** *inground lift preventative maintenance system*

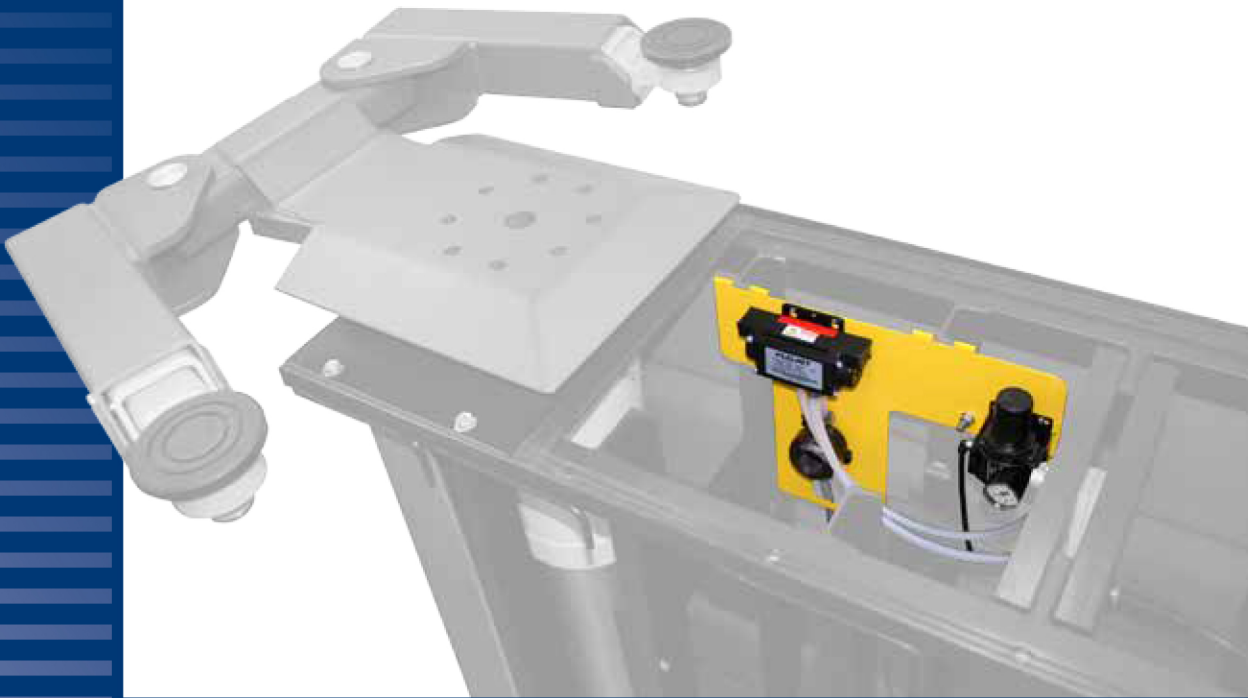

### **Available for all Challenger Lifts Inground Lift Models!**

Challenger Lifts' Stay Dry Preventative Maintenance System is the most effective tool against inground lift condensation accumulation to date. Due to varying climates, shop temperatures and atmospheric pressure changes, moisture may collect at the bottom of the containment tub. Overtime, this accumulation can add up to a significant amount.

Stay Dry is an automatic preventative maintenance tool which is pneumatically powered off of the existing internal air safety system supply line. As the lift operator disengages the air actuated safety locks to lower the lift, an internally mounted flojet pump quietly siphons any accumulated condensate from the floor of the lift containment system out through the hydraulic chase tube.

#### **Features:**

- Automatically displaces condensate from tub bottom when lift is lowered
- Can easily be retrofitted to older lift models and competitive brands
- Eliminates costly maintenance calls and lift downtime for servicing
- Prolongs the life of the inground lift and its hydraulic components



**Contact your Rotunda area Sales Manager  
or your Field Service Engineer**

**1-800-ROTUNDA [www.OneRotunda.com](http://www.OneRotunda.com)**